

BJC-1000

SERVICE MANUAL

REVISION 0

Canon

DEC. 1998

QY8-1364-000

1298 SC 0.40-0

BJC-1000

SERVICE MANUAL

Canon

Application

This manual has been issued by Canon Inc. for qualified persons to learn technical theory, installation, maintenance, and repair of products. This manual covers all localities where the products are sold. For this reason, there may be information in this manual that does not apply to your locality.

Corrections

This manual could include technical inaccuracies or typographical errors due to improvements or changes in the products. When changes occur in applicable products or in the content of this manual, Canon will release technical information as the need arises. In the event of major changes in the contents of this manual over a long or short period, Canon will issue a new edition of this manual.

The following paragraph does not apply to any countries where such provisions are inconsistent with local law.

Trademarks

The product names and company names described in this manual are the registered trademarks of the individual companies.

Copyright

This manual is copyrighted with all rights reserved. Under the copyright laws, this manual may not be copied, reproduced or translated into another language, in whole or in part, without the written consent of Canon Inc., except in the case of internal business use.

Copyright © 1998 by Canon Inc.

CANON INC.

BJ Products Technical Support Dept

16-1, Shimonoge 3-chome, Takatsu-ku, Kawasaki-shi, Kanagawa 213-8512, Japan

This manual was produced on an Apple Macintosh™ Power Mac 8500/180 personal computer and Apple LaserWriter™ 16/600PS-J laser beam printer; final pages were printed on Varityper™ 5300 with 4000-J RIP. All graphics were produced with MACROMEDIA® FREEHAND® 7.0J. All documents and all page layouts were created with QuarkXPress™ 3.3J.

I. ABOUT THIS MANUAL

This manual is divided into five sections, and contains information required for servicing the unit.

Part 1: Safety and Precautions

This section tells you how to service the unit safely. It is very important, so please read it.

Part 2: Product Specifications

This section outlines the products specifications.

Part 3: Operating Instructions

This section explains how to operate the unit properly, and contains information required for installation and service.

Part 4: Technical Reference

This section outlines the way the unit operates so you can understand it technically.

Part 5: Maintenance

This section explains how to maintain the unit. Descriptions of assembly/disassembly, adjustment for assembly, troubleshooting procedures, and wiring/circuit diagrams are given.



Procedures for assembly/disassembly are not given in this manual.
See the illustrations in the separate *Parts Catalog*.

II. TABLE OF CONTENTS

	<i>Part 1: Safety and Precautions</i>
1 - 1	1. PERSONAL SAFETY PRECAUTIONS
1 - 1	1.1 Moving and Rotating Parts
1 - 2	1.2 Ink Stains
1 - 2	1.2.1 Ink path
1 - 3	1.2.2 Ink mist
1 - 4	2. MACHINE PRECAUTIONS
1 - 4	2.1 Precautions for Handling BJ Cartridges
1 - 4	2.1.1 Turning the printer ON/OFF
1 - 4	2.1.2 When the printer is not in use
1 - 4	2.1.3 Transportation precautions
1 - 5	2.1.4 Ink electroconductivity
1 - 5	2.2 Printer Handling
1 - 5	2.2.1 Spur deformation prevention
1 - 6	2.2.2 Precautions to prevent damage from static electricity
1 - 6	2.2.3 Ink leakage precautions
1 - 7	3. PRECAUTIONS FOR SERVICE
1 - 7	3.1 EEPROM Data Precautions
1 - 8	3.2 Static Electricity Precautions
1 - 9	3.3 Disassembly and Reassembly Precautions
1 - 9	3.4 Built-in Self-diagnostic Functions
	 <i>Part 2: Product Specifications</i>
2 - 1	1. PRODUCT OUTLINE
2 - 1	1.1 Product Outline
2 - 2	1.2 Features
2 - 3	1.3 BJ Cartridge
2 - 3	1.3.1 Color and Photo BJ cartridges
2 - 3	1.3.2 Black BJ cartridge
2 - 4	1.4 BJ Cartridge Container
2 - 4	1.5 Consumables
2 - 4	1.5.1 BJ cartridges (Black, Color, and Photo)
2 - 5	2. SPECIFICATIONS
2 - 5	2.1 General Specifications
2 - 7	2.2 Paper Specifications
2 - 7	2.2.1 Paper setting
2 - 8	2.2.2 Printing range
2 - 9	2.3 Interface Specifications
	 <i>Part 3: Operating Instructions</i>
3 - 1	1. PRINTER SETUP
3 - 1	1.1 Equipment Check
3 - 2	1.2 Printer Dimensions
3 - 3	1.3 Setup Procedure
3 - 3	1.3.1 Connecting the interface cable
3 - 3	1.3.2 Turning on the printer
3 - 4	1.3.3 Installing the cartridge
3 - 5	1.3.4 BJ cartridge container
3 - 6	1.4 Turning the Printer On/Off
3 - 6	1.4.1 Turning the printer on
3 - 6	1.4.2 Turning the printer off
3 - 7	1.5 Paper Settings
3 - 7	1.6 Banner Printing

Page	
3 - 8	1.7 Name of the Parts and Their Functions
3 -10	2. PRINTER SERVICING FUNCTIONS
3 -10	2.1 Error Indications
3 -11	2.2 Cleaning the BJ Cartridge
3 -11	2.3 Self-Test Printout
3 -11	2.3.1 Nozzle check pattern
3 -12	2.3.2 Service test print
3 -13	2.4 EEPROM Reset
3 -13	2.4.1 EEPROM Reset
3 -13	2.4.2 Printing the EEPROM data

Part 4: Technical Reference

4 - 1	1. OVERVIEW
4 - 1	1.1 Block Diagram
4 - 2	1.2 Printing Signal Flow
4 - 3	1.3 Print Drive
4 - 3	1.3.1 Printing drive control
4 - 5	2. FIRMWARE
4 - 5	2.1 720 dpi Printing/Smoothing Feature
4 - 5	2.1.1 Canon extension mode
4 - 6	2.2 Printing Modes
4 - 6	2.2.1 Printing mode
4 - 7	2.3 Optimum Printing Direction Control
4 - 8	3. PRINTER MECHANICAL SYSTEM
4 - 8	3.1 Overview
4 - 8	3.1.1 Mechanical components
4 -10	3.2 BJ Cartridge
4 -10	3.2.1 Black BJ cartridge structure
4 -11	3.2.2 Color/Photo BJ cartridge structure
4 -12	3.2.3 Bubble head unit structure
4 -17	3.3 Purge Unit
4 -17	3.3.1 Purge unit functions
4 -18	3.3.2 Purge unit structure
4 -19	3.4 Carriage
4 -19	3.4.1 Carriage functions
4 -20	3.4.2 Carriage structure
4 -22	3.5 Paper Feed
4 -22	3.5.1 Outline of the paper feed
4 -23	3.5.2 Structure of the sheet feeder
4 -24	4. PRINTER ELECTRICAL SYSTEM
4 -24	4.1 Overview
4 -25	4.2 Logic Section
4 -25	4.2.1 Logic section block diagram
4 -26	4.2.2 Logic section components
4 -28	5. SENSOR FUNCTIONS
4 -28	5.1 Pick-Up Roller Sensor
4 -28	5.2 Paper End Sensor
4 -28	5.3 Home Position Sensor (Purge Sensor)
4 -29	5.4 Temperature Sensor
4 -29	5.5 Waste Ink Amount Detection

Page

Part 5: Maintenance

5 - 1	1. MAINTENANCE & SERVICING TOOLS
5 - 1	1.1 Maintenance
5 - 1	1.1.1 Parts for Regular Replacement
5 - 1	1.1.2 Consumables
5 - 1	1.1.3 Periodic Maintenance
5 - 1	1.2 Servicing Tools
5 - 2	2. GREASE APPLICATION
5 - 3	3. DISASSEMBLY AND REASSEMBLY
5 - 3	3.1 Disassembly and Reassembly
5 - 3	3.2 Disassembly and Reassembly Cautions
5 - 4	3.3 Logic Board and Bottom Cover Replacement Cautions
5 - 4	3.3.1 Logic board replacement cautions
5 - 4	3.3.2 Cautions after replacing the bottom cover
5 - 5	4. TROUBLESHOOTING
5 - 5	4.1 Troubleshooting
5 - 5	4.1.1 Overview
5 - 5	4.1.2 Troubleshooting cautions
5 - 7	4.2 Error Condition Diagnosis
5 - 7	4.2.1 Initial self check
5 - 9	4.2.2 Error recovery
5 -21	5. LOCATION & SIGNAL ASSIGNMENT
5 -21	5.1 Logic Board
5 -23	5.2 Carriage Ribbon Cable
5 -24	5.3 BJ Cartridges
5 -25	6. CIRCUIT DIAGRAMS
5 -25	6.1 Parts Layout
5 -25	6.1.1 Logic board
5 -27	6.2 Circuit Diagram

III. ILLUSTRATION INDEX

Page	
1 - 1	Figure 1- 1 Moving and Rotating Parts
1 - 2	Figure 1- 2 Ink Path
1 - 3	Figure 1- 3 Ink Mist
1 - 4	Figure 1- 4 Storing the BJ Cartridge
1 - 5	Figure 1- 5 Spurs
1 - 6	Figure 1- 6 Contact Section of the Carriage Ribbon Cable
1 - 6	Figure 1- 7 Capping Position
1 - 8	Figure 1- 8 Printer Electrical System
1 - 9	Figure 1- 9 How to Release Plastic Hooks
2 - 1	Figure 2- 1 Printer Appearance
2 - 3	Figure 2- 2 Color and Photo BJ Cartridges
2 - 3	Figure 2- 3 Black BJ Cartridge
2 - 4	Figure 2- 4 BJ Cartridge Container
2 - 4	Figure 2- 5 Consumables
2 - 8	Figure 2- 6 Printing Area
2 - 8	Figure 2- 7 Printing Area (Envelope)
2 - 8	Figure 2- 8 Printing Area (Banner Paper)
2 -13	Figure 2- 9 Timing Chart (Compatible Mode)
2 -13	Figure 2-10 Timing Chart (Nibble Mode)
3 - 1	Figure 3- 1 Packaging
3 - 2	Figure 3- 2 Printer Dimensions
3 - 3	Figure 3- 3 Connecting the Interface Cable
3 - 4	Figure 3- 4 Removing the BJ Cartridge Protectors
3 - 4	Figure 3- 5 BJ Cartridge Handling Precautions
3 - 5	Figure 3- 6 Cartridge Installation
3 - 5	Figure 3- 7 BJ Cartridge Container
3 - 6	Figure 3- 8 Never unplug the power cord less than one minute after completing an operation
3 - 7	Figure 3- 9 Banner Printing
3 - 8	Figure 3-10 Name of the Parts and Their Functions (1)
3 - 9	Figure 3-11 Name of the Parts and Their Functions (2)
3 - 9	Figure 3-12 Paper Thickness Lever
3 -11	Figure 3-13 Nozzle Check Pattern
3 -12	Figure 3-14 Service Test Print
4 - 1	Figure 4- 1 Block Diagram
4 - 2	Figure 4- 2 Printing Signal Flow
4 - 3	Figure 4- 3 Nozzle Arrangement
4 - 4	Figure 4- 4 Printing Signals
4 - 5	Figure 4- 5 720 dpi Printing/Smoothing Feature
4 - 8	Figure 4- 6 Printer's Mechanical Configuration
4 -10	Figure 4- 7 Black BJ Cartridge Structure
4 -11	Figure 4- 8 Color/Photo BJ Cartridge Structure
4 -12	Figure 4- 9 Bubble Jet Nozzles (Partial View)
4 -13	Figure 4-10 Nozzle Arrangement
4 -13	Figure 4-11 Contact Pad
4 -14	Figure 4-12 Bubble Jet Head Driver Block Diagram (Black BJ Cartridge)
4 -14	Figure 4-13 Bubble Jet Head Driver Block Diagram (Color BJ Cartridge)
4 -15	Figure 4-14 Bubble Jet Head Driver Block Diagram (Photo BJ Cartridge)
4 -15	Figure 4-15 Head Rank ID
4 -16	Figure 4-16 Head Temperature Controller
4 -18	Figure 4-17 Purge Unit
4 -19	Figure 4-18 Carriage

Page		
4 -20	Figure 4- 19	Paper Thickness Adjustment
4 -21	Figure 4- 20	Paper Feed Motor Drive Transmission
4 -22	Figure 4- 21	Paper Feed Mechanism
4 -23	Figure 4- 22	Paper Separator
4 -24	Figure 4- 23	Printer Electrical System
4 -25	Figure 4- 24	Logic Board Block Diagram
4 -25	Figure 4- 25	Printer Block Diagram
4 -28	Figure 4- 26	Sensors
5 - 2	Figure 5- 1	Grease Application Points
5 - 4	Figure 5- 2	Bottom Cover
5 -21	Figure 5- 3	Logic Board
5 -23	Figure 5- 4	Carriage Ribbon Cable
5 -24	Figure 5- 5	Contact Pad
5 -25	Figure 5- 6	Logic Board (Top View)
5 -26	Figure 5- 7	Logic Board (Bottom View)

IV. TABLE INDEX

Page		
3 - 7	TABLE 3- 1	QUICK REFERENCE FOR SETTING
3 -10	TABLE 3- 2	ERROR INDICATIONS
3 -13	TABLE 3- 3	DEFAULT SETTING WHEN RESETTING THE EEPROM
4 - 6	TABLE 4- 1	PRINTING MODES AND HEATING METHODS
4 -29	TABLE 4- 2	LIST OF SENSOR FUNCTIONS
5 -23	TABLE 5- 1	BJ CARTRIDGE RECOGNITION

This page intentionally left blank



Part 1

SAFETY AND PRECAUTIONS

Page	
1 - 1	1. PERSONAL SAFETY PRECAUTIONS
1 - 1	1.1 Moving and Rotating Parts
1 - 2	1.2 Ink Stains
1 - 4	2. MACHINE PRECAUTIONS
1 - 4	2.1 Precautions for Handling BJ Cartridges
1 - 5	2.2 Printer Handling
1 - 7	3. PRECAUTIONS FOR SERVICE
1 - 7	3.1 EEPROM Data Precautions
1 - 8	3.2 Static Electricity Precautions
1 - 9	3.3 Disassembly and Reassembly Precautions
1 - 9	3.4 Built-in Self-diagnostic Functions

1. PERSONAL SAFETY PRECAUTIONS

1.1 Moving and Rotating Parts

Be careful not to let your hair, clothes, accessories, etc., become caught up in the moving and rotating parts of the printer. The moving and rotating parts, the carriage belt, idler roller, and carriage, are driven by the carriage motor, and the slow down gear, paper feed roller, pressure roller, eject roller, spurs, and pick-up roller, etc., are driven by the paper feed motor.

Be careful not to touch the spurs as they are sharply pointed.

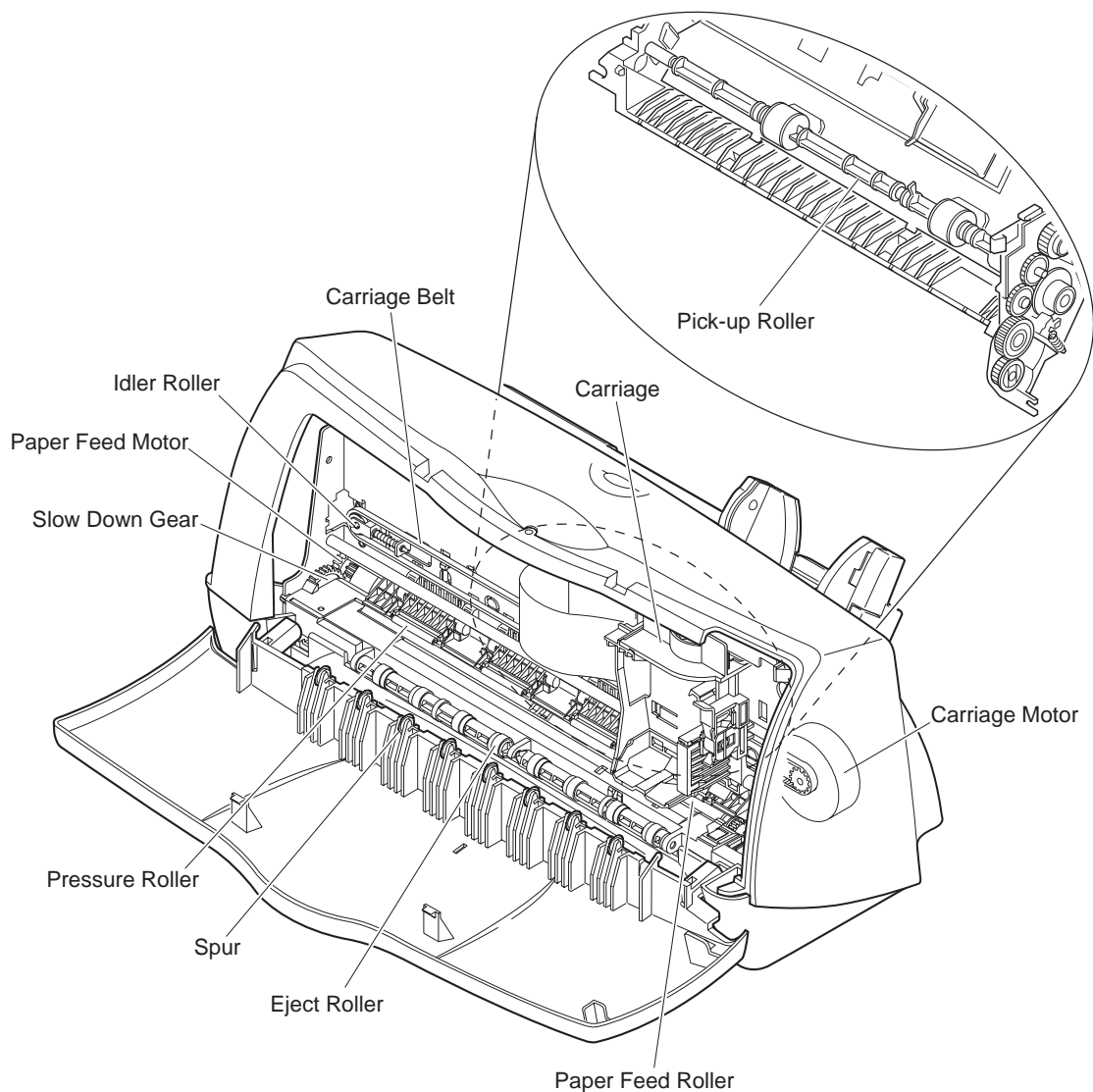

Figure 1-1 Moving and Rotating Parts

1.2 Ink Stains

1.2.1 Ink path

Be careful not to touch the ink path as it may stain the printer, your hands, or clothes during repair.

The ink path is the nozzle section of the BJ cartridge, head cap, head wiper, maintenance jet receiving section, and the waste ink absorbers.

For the color BJ cartridge, the ink inlets of the ink cartridge and the joint pipes of the print head body are also part of the ink path, so take the same care with them.



CAUTION

The ink is not a harmful substance to the human body, but it does contain organic solvents.

Black ink: isopropyl alcohol 67-63-0, glycerin 56-81-5

Color ink: isopropyl alcohol 67-63-0, glycerin 56-81-5

Take care not to get ink in the mouth or eyes. If ink does get into the eyes, wash it out with plenty of water and consult a doctor immediately. If, for some reason, a large amount of the ink is swallowed, consult a doctor immediately.

Please provide the doctor with the information printed on the BJ cartridge label. This ink contains dyes, and cannot be removed from clothing, etc.

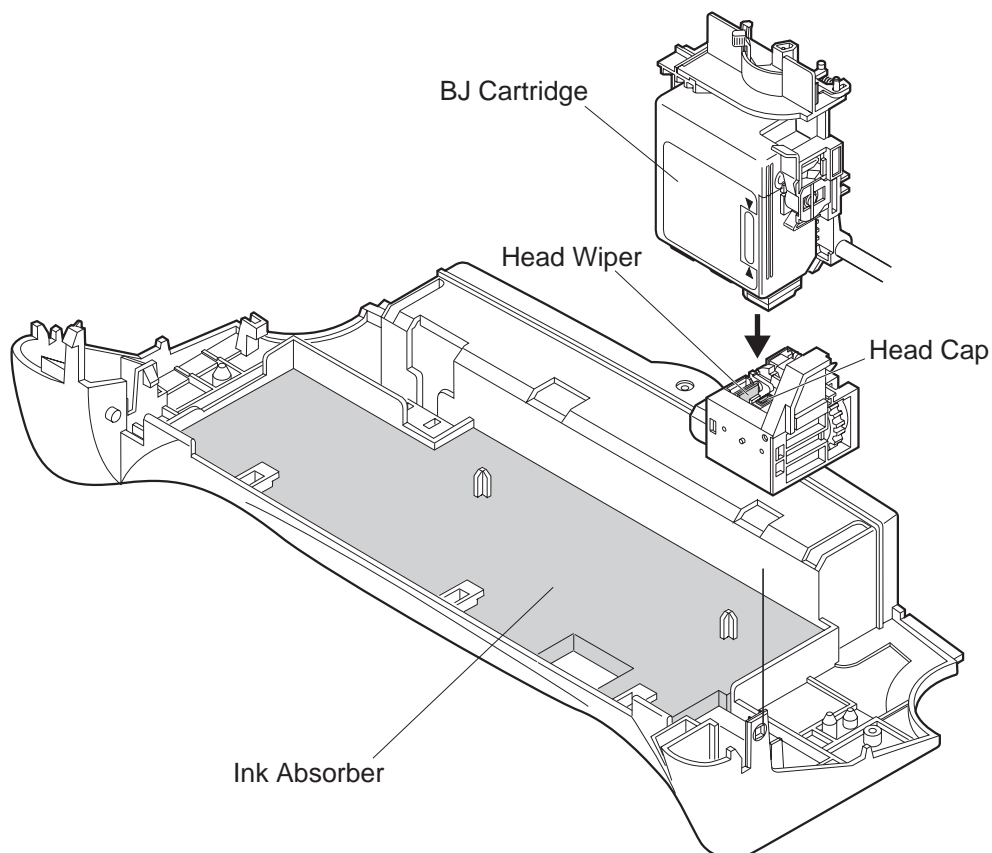

Figure 1-2 Ink Path

1.2.2 Ink mist

The BJ cartridge ejects ink onto the paper. However, after the printer has been used for a long period of time or under heavy duty use, a small amount of ink mist bouncing back off the paper during printing can dirty the inside of the front cover and platen area.

Wipe the dirty areas with a soft damp cloth as this ink can dirty the paper, or the hands or clothing of service personnel.

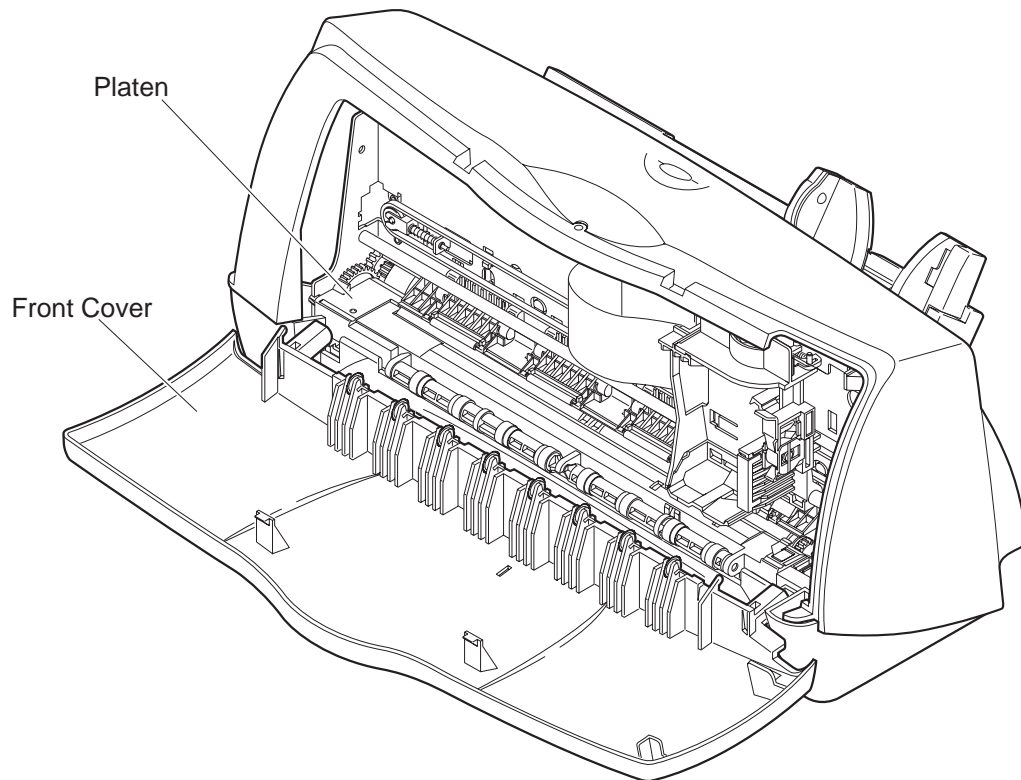

Figure 1-3 Ink Mist

2. MACHINE PRECAUTIONS

2.1 Precautions for Handling BJ Cartridges

2.1.1 Turning the printer ON/OFF

The printer will automatically cap the cartridge heads one minute after printing operations are completed, to prevent the ink from leaking or drying out.

When unplugging the power cord, wait at least one minute after completing an operation such as printing, feeding paper, cleaning the print head, etc.

If the power cord is accidentally unplugged before one minute has passed, replug the AC adapter and wait for more than one minute before unplugging the power cord.



If the nozzles are not capped, the ink may leak or dry out, causing the nozzles to clog.

2.1.2 When the printer is not in use

BJ cartridges should be stored either installed in the printer or in the BJ cartridge container.



If the BJ cartridge is removed from the printer or BJ Cartridge Container, the ink may leak or dry out, causing the nozzles to clog.

2.1.3 Transportation precautions

When transporting the printer, follow the procedure below.

- 1) Disconnect the interface cable and AC power cord as described above in *Part 3: 1.3 Setup Procedure (page 3-3)*.
- 2) Put the BJ cartridge in the BJ cartridge container.
- 3) Repack the printer in its original box and packing materials.

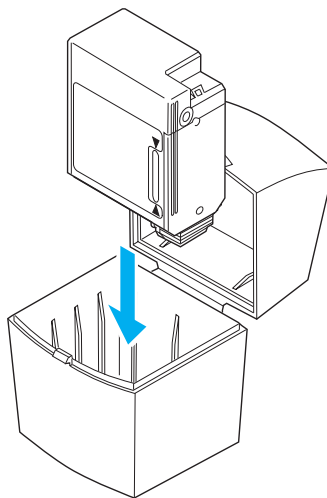

Figure 1-4 Storing the BJ Cartridge



If you do not have the original packing materials, use an ample amount of shock-absorbing materials.

2.1.4 Ink electroconductivity

The ink in the BJ cartridge is electroconductive. If ink leaks into the printer's mechanical parts, use a damp paper towel, etc., to wipe clean. If it leaks into the printer's electrical components, use tissue paper, etc., to wipe clean completely. If ink gets into the IC chips on the PCB and it is difficult to clean, replace the PCB.



If ink has leaked inside the printer, do not plug in the power cord. It may damage the circuitry.

2.2 Printer Handling

2.2.1 Spur deformation prevention

Do not deform the spurs. If spurs are deformed, their contact area with the printed paper increases, causing more ink to adhere. This can lead to the paper becoming stained with ink. (A dotted line may appear where the spurs have contacted the paper.)

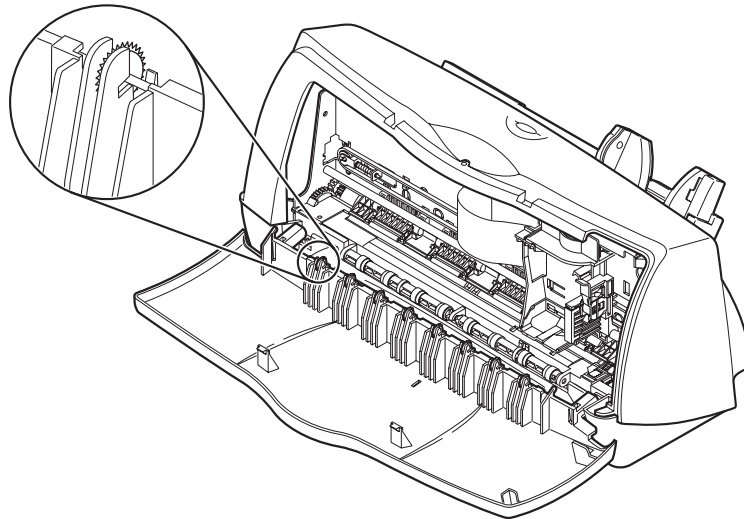

Figure 1-5 Spurs

2.2.2 Precautions to prevent damage from static electricity

The electrostatic charge accumulated on clothing can damage electric elements and their characteristics. Do not touch the contact points of the carriage ribbon cable and BJ cartridge.

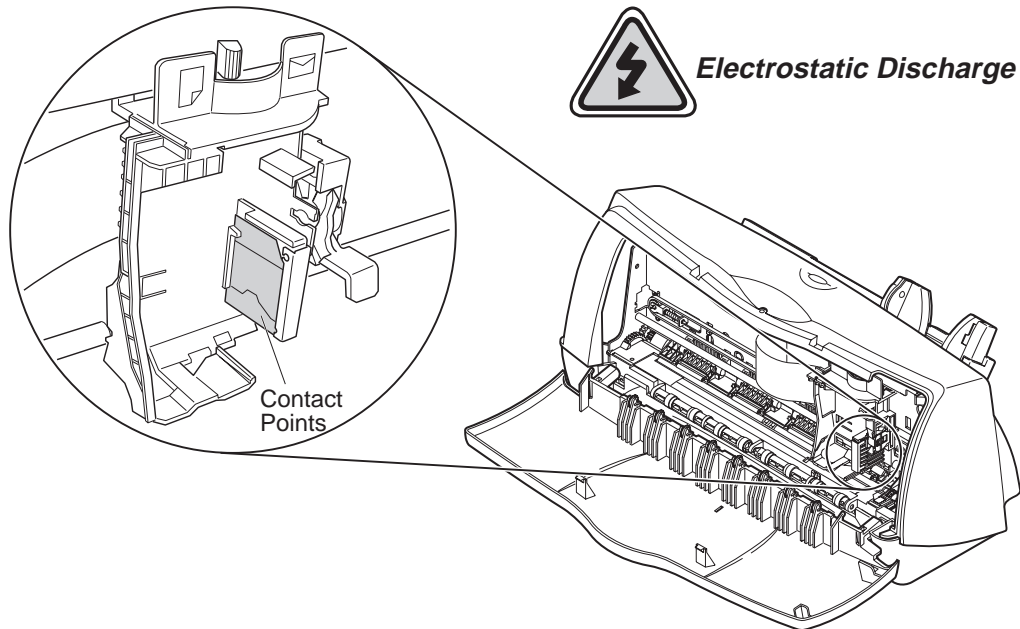

Figure 1-6 Contact Section of the Carriage Ribbon Cable

2.2.3 Ink leakage precautions

Do not carry, pack or store the printer without a BJ cartridge installed. The ink within the purge unit may flow back and contaminate the inside of the printer. When packing up the printer, make sure the carriage is in the capping position (the right end of the platen).

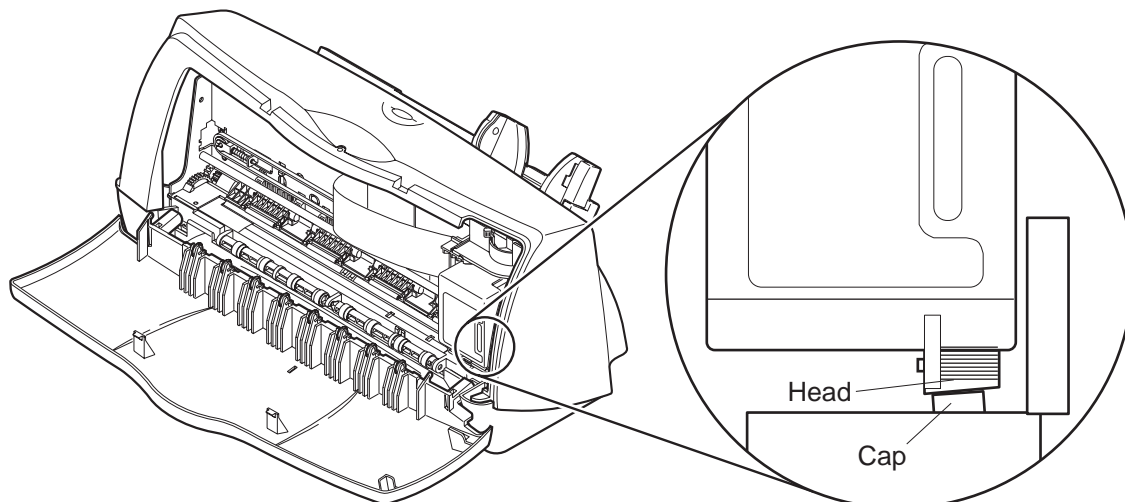

Figure 1-7 Capping Position

3. PRECAUTIONS FOR SERVICE

3.1 EEPROM Data Precautions

The printer keeps track of various settings, the total waste ink amount, and the total sheets printed with the black, color and photo BJ cartridges. This data is stored in the EEPROM on the logic board. Note the following precautions during servicing:

1) Before servicing

Check the EEPROM data with a test print. The total sheets printed can give you an idea of how much the printer has been used.

2) During logic board (EEPROM) replacement

Always visually check the waste ink amount absorbed by the waste ink absorbers and replace them when necessary as explained in *Part 5: 3.3 Logic Board and Bottom Cover Replacement Cautions (page 5-4)*.

If the waste ink absorbers are not visually checked regularly, they may reach or exceed their full capacity before “waste ink full” is detected. The waste ink may therefore start leaking.

The memory data for the replacement logic board (EEPROM) is not defined.

Therefore, after replacing the logic board (and EEPROM), reset the total waste ink amount to zero by clearing the data.

3) After bottom cover unit replacement

After replacing the bottom cover unit, reset the total waste ink amount to zero by clearing the EEPROM data.



After the EEPROM is reset, the data it contained cannot be printed out with a test printout. If you want to check the stored data, be sure to execute test printout before resetting the EEPROM.

When the stored data is reset, the various settings, the total count of printed sheets, and the total waste ink amount will all be reset. The total sheets printed and waste ink amount cannot be input using the operation panel.



Immediately after the printer is turned on, it keeps track of the estimated waste ink amount based on the usage conditions. To prevent ink leakage when the waste ink amount exceeds the waste ink absorption capacity, the printer stops printing and indicates an error when the waste ink absorption capacity is close to being full.

For details on checking the EEPROM data with a test printout and for clearing the data, see *Part 3: 2.4 EEPROM Reset (page 3-13)*.

If the printer stops operating in the case of a waste ink full error, follow the countermeasures described in *Part 5: 4.1 Troubleshooting (page 5-5)*.

3.2 Static Electricity Precautions

The electrostatic charge accumulated in clothing can damage electric elements and their characteristics. In order to prevent static electricity, touch a metallic part that is grounded to release the static electricity before disassembling the printer for servicing. Before discharging static electricity, do not touch electrical sections such as the logic board and contact points of the carriage ribbon cable (see *Figure 1-6*) when the carriage ribbon cable is connected to the logic board.

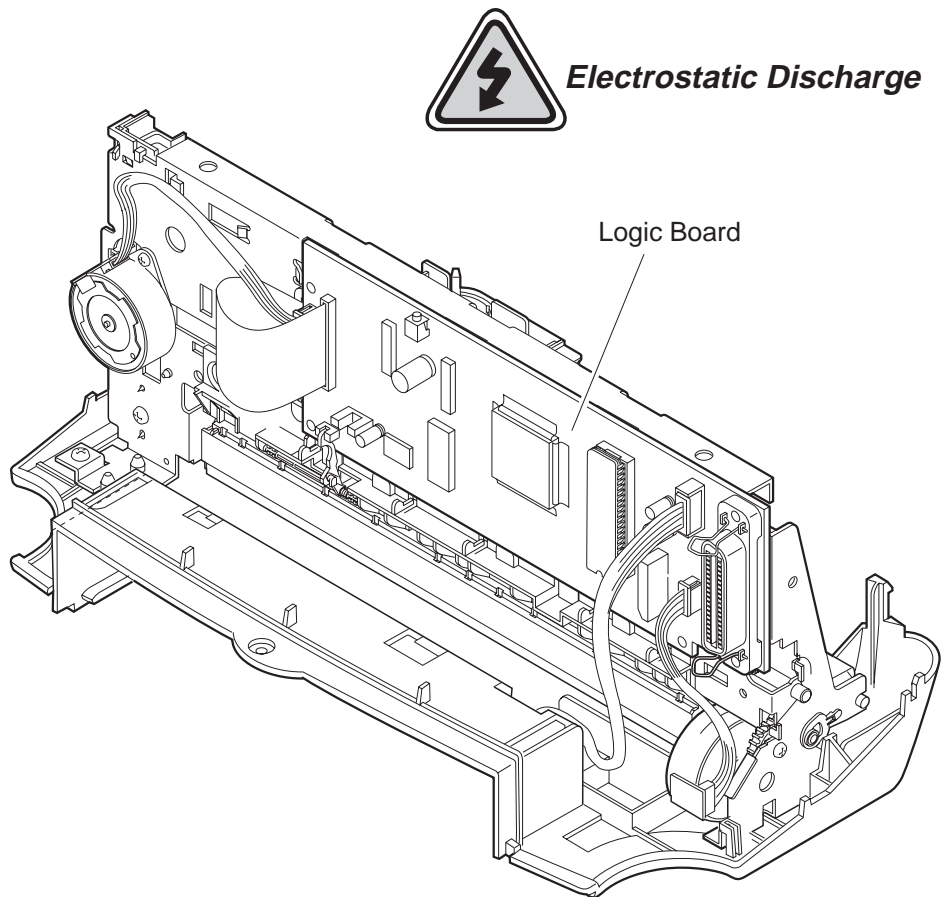

Figure 1-8 Printer Electrical System

3.3 Disassembly and Reassembly Precautions

The printer is comprised of a large number of plastic parts. When disassembling the printer, take care not to break or bend plastic hooks.



Some plastic parts contain glass fibers for extra rigidity and precision, but since their viscosity is low, plastic hooks can break easily when excessive force is used. Use a precision screwdriver, and do not pull plastic hooks with excessive force when unhooking them.

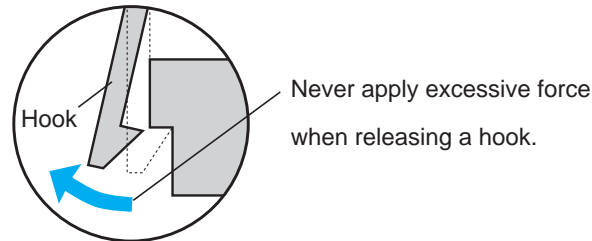

Figure 1-9 How to Release Plastic Hooks

3.4 Built-in Self-diagnostic Functions

The printer has built-in self-diagnostic functions to detect hardware defects. The results of self-diagnosis are indicated on the host computer's screen as an error. (The host computer should be set in nibble mode, and use the BJ status monitor under Windows 95/98.) For details, refer to *Part 3: 2.1 Error Indications (Page 3-10)*.

This page intentionally left blank



Part 2

PRODUCT SPECIFICATIONS

Page	
2 - 1	1. PRODUCT OUTLINE
2 - 1	1.1 Product Outline
2 - 2	1.2 Features
2 - 3	1.3 BJ Cartridge
2 - 4	1.4 BJ Cartridge Container
2 - 4	1.5 Consumables
2 - 5	2. SPECIFICATIONS
2 - 5	2.1 General Specifications
2 - 7	2.2 Paper Specifications
2 - 9	2.3 Interface Specifications

1. PRODUCT OUTLINE

1.1 Product Outline

This printer enjoys the realization of photo-like high image quality printing. The printer uses three types of BJ cartridges: the color BJ cartridge, the photo BJ cartridge and the black BJ cartridge. The printer is capable of high-speed, high-quality 360 dpi X 360 dpi (H X V) printing. Also, with the black BJ cartridge, smoothing can be used to obtain a resolution of 720 dpi X 360 dpi (H X V). This new compact printer is light in weight and very economically priced.

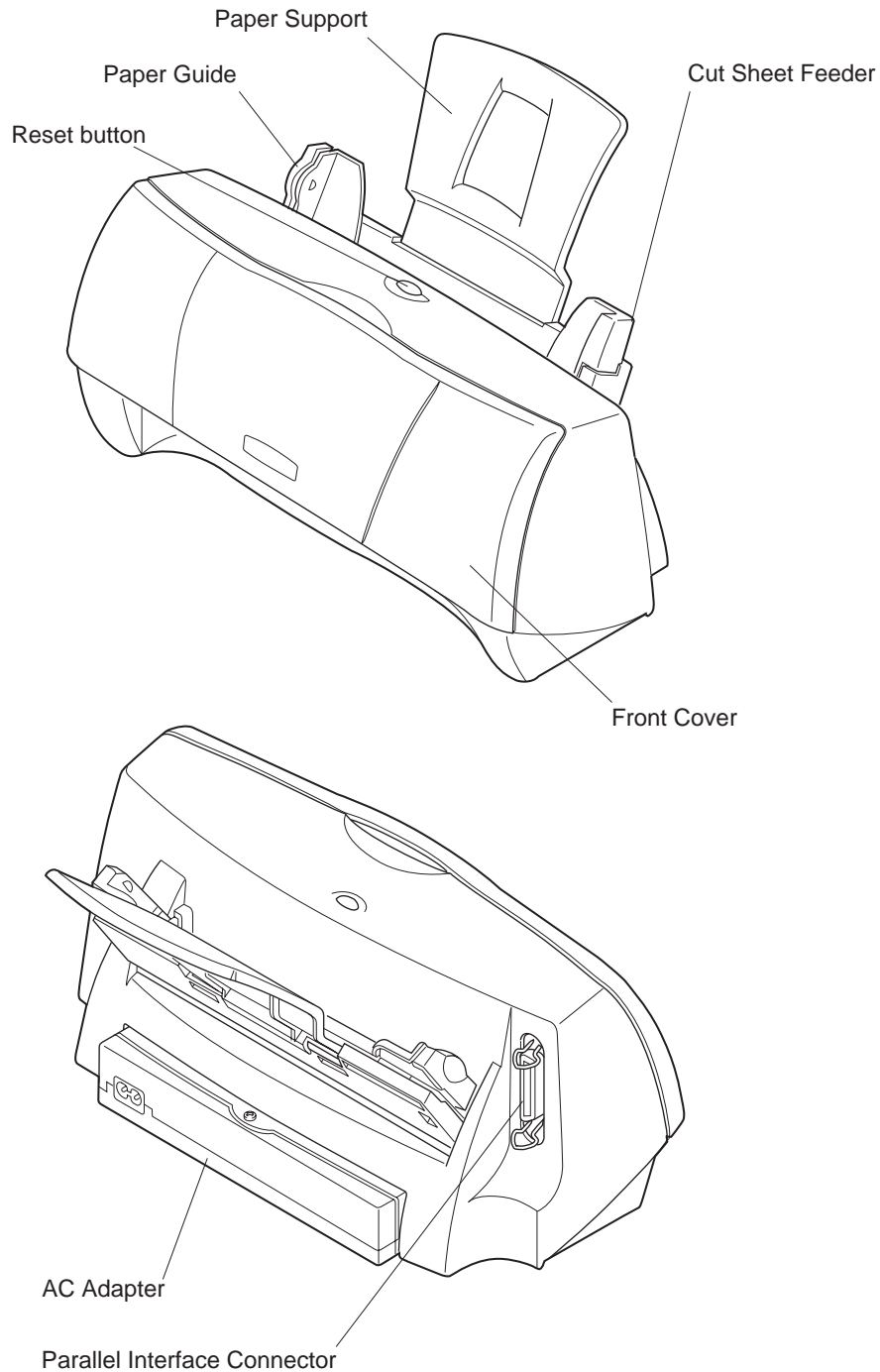

Figure 2-1 Printer Appearance

1.2 Features

1. Compact (desk-top size)
External dimensions: 360 mm (W) × 174 mm (D) × 160 mm (H)
Weight: Approx. 2.2 kg (4.9 lbs) (excluding BJ cartridge and options)
2. Only *RESUME* button on the operation panel (No LED and buzzer)
Errors will be displayed on the host computer monitor. (The host computer should be set to Nibble mode and use the BJ status monitor with Windows95/98.)
3. New AC adapter
4. High quality printing of 720 × 360 dpi
(Smoothing: With black BJ cartridge BC-02 and exclusive printer driver)
5. Windows exclusive printer (used with the Canon original printer driver)
6. Photo printing capability
7. Banner printing capability
8. New image processing technology "Image Optimizer" supported by the driver.
(Image optimizer: a function to reduce "jaggies" which occur when enlarging low resolution images.)
9. Improved printer driver color matching processing
10. Device ID and status response function compatible with Windows95/98 Plug & Play
(Responds to the device ID/status of nibble mode)
11. New leverless sheet feeder
12. New carriage

1.3 BJ Cartridge

1.3.1 Color and Photo BJ cartridges

The color and photo BJ cartridges each contain 3 ink colors; yellow, magenta and cyan. With these 3 colors, composite black can be produced.

The first 16 nozzles are for yellow, the following 8 nozzles are unused, the second 16 nozzles are for magenta, then 8 nozzles unused, and the third 16 nozzles are for cyan. They are lined vertically.

When using the color or photo BJ cartridge, 360 (H) × 360 (V) dpi printing is possible. Photo-like printing can be realized by using the photo BJ cartridge.

Use the high resolution paper HR-101 when printing with photo BJ cartridge.

Since the three color inks in the color and photo BJ cartridge are integrated, when one color ink runs out, the BJ cartridge must be replaced. Also, when more than 6 months have passed after the cartridge is unpacked, or if the printing quality is not improved even after cleaning the head over five times, replace the BJ cartridge.

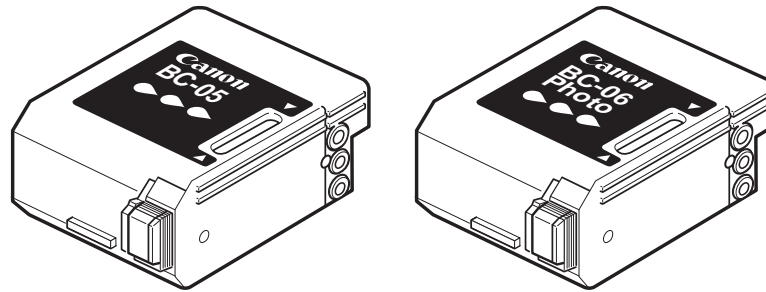

Figure 2-2 Color and Photo BJ Cartridges

1.3.2 Black BJ cartridge

The black BJ cartridge holds black ink only. The print head has 64 nozzles, all of which are used for black printing.

When using the black BJ cartridge in the smoothing mode, 720 (H) × 360 (V) dpi printing is possible.

When the ink runs out, or more than 6 months have passed after the cartridge is unpacked, or if the printing quality is not improved even after cleaning the head over five times, replace the black BJ cartridge.

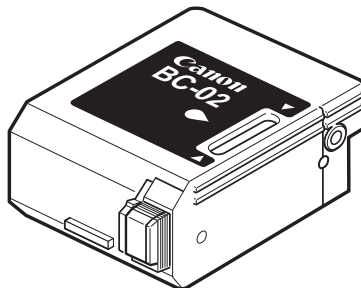

Figure 2-3 Black BJ Cartridge

1.4 BJ Cartridge Container

The cartridge container is used for storing a BJ cartridge which is not being used. When storing a BJ cartridge in this container, be sure to close the cover completely. Store a BJ cartridge, which are not installed in the printer.

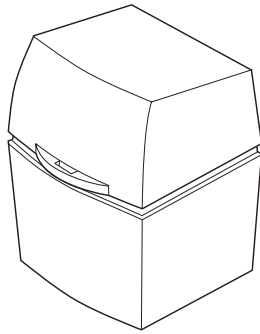
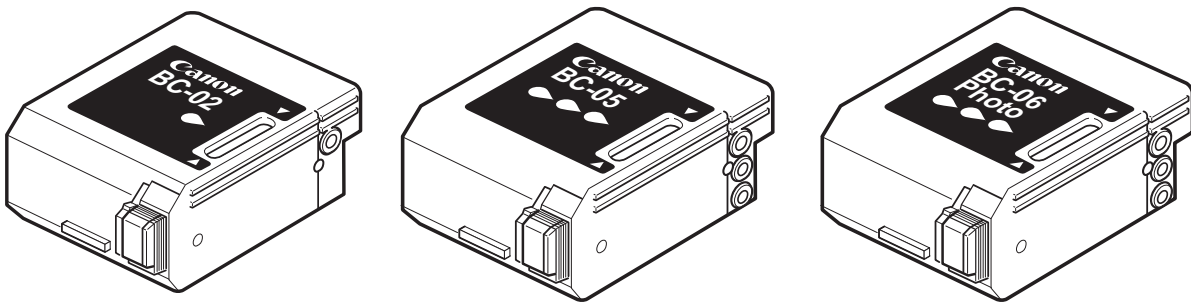

Figure 2-4 BJ Cartridge Container

1.5 Consumables

1.5.1 BJ cartridges (Black, Color, and Photo)



Black BJ Cartridge

Color BJ Cartridge

Photo BJ Cartridge

Figure 2-5 Consumables

The numbers of sheets that can be printed with the color and black cartridges are :

Black BJ cartridge (BC-02)

About 450 sheets : (HQ mode, 1500 character pattern, continuous printing)

Color BJ cartridge (BC-05)

About 80 sheets: (HQ mode, 7.5% duty per color pattern*, continuous printing)

About 100 sheets: (HQ mode, 7.5% duty per color pattern*, intermittent printing)

Photo BJ cartridge (BC-06 photo)

About 45 sheets: (HQ mode, 7.5% duty per color pattern*, continuous printing)

* Color print pattern for C/M/Y/Bk

2. SPECIFICATIONS

2.1 General Specifications

1. Type

Desktop serial color bubble jet printer

2. Paper feeding method

Auto sheet feed

3. Resolution

720 dpi X 360 dpi

(Smoothing: With black BJ cartridge and exclusive printer driver)

4. Stacking capacity of sheet feeder

Plain paper Max. 5 mm stack (approx. 50 pages with 75 g/m² paper)

LGL size: Max. 10 pages

Envelopes 5 envelopes

Post card 20 pages

Transparencies 20 pages

Back print film 10 pages

Glossy photo paper 1 page

High gloss film 1 page

Fabric 1 page

T-shirt transfer 1 page

Banner paper 1 page

5. Paper size

Letter (8.5" X 11")

Legal (8.5" X 14")

A5 (148 mm X 210 mm)

A4 (210 mm X 297 mm)

Commercial number 10 envelopes (4.11" X 9.5")

European DL-size envelopes (220 mm X 110 mm)

6. Paper type

Plain paper

Envelopes (Commercial number 10 or European DL-size)

Transparencies (Canon Transparencies CF-102)

Back print film (Canon Back Print Film BF-102)

Glossy photo paper (Canon Glossy Photo Paper GP-301)

High gloss film (Canon High Gloss Film HG-101)

High resolution paper (Canon High Resolution Paper HR-101)

Bubble jet paper (Canon Bubble Jet Paper LC-301)

Fabric (Canon Fabric Sheet FS-101)

Banner paper (Canon Banner Paper BP-101)

T-shirt transfer (Canon T-Shirt Transfer TR-201)

7. Paper weight

Automatic feed 64 to 105g/m² (17 lbs to 28 lbs)

8. Printing speed (Throughput)

	Color printing (BC-05)	Monochrome printing (BC-02)
HQ mode	0.5 ppm	3.2 ppm
HS mode	0.6 ppm	4.0 ppm

9. Printing direction

Switching unidirectional
(Printing direction automatically changes according to the print data/print mode/installed cartridge type)

10. Print width

Max. 203.2 mm (8")

11. Line feed speed

Approx. 80 ms/line (64/360" line feed)

12. Built-in print control mode

Canon extended mode is supported when using the Canon original printer driver.

13. Receive buffer

10 KBytes

14. Interface

IEEE1284 compatible 8-bit parallel

15. BJ cartridges**BC-02 (black BJ cartridge)**

Print head	64 nozzles in a vertical line
Ink color	Black
No. of pages printable	Approx. 450 pages (HQ mode, 1500 character pattern, continuous printing)
Weight	Approx. 58.5g (2.1 oz)

BC-05 (color BJ cartridge)

Print head	48 nozzles in a vertical line: YMC (16 nozzles X 3)
Ink color	Cyan, magenta, yellow (Black is composite black.)
No. of pages printable	Approx. 80 pages (HQ mode, YMCK 7.5% duty per color pattern, continuous printing)
Weight	Approx. 62g (2.2 oz)

BC-06 Photo (photo BJ cartridge)

Print head	48 nozzles in a vertical line: YMC (16 nozzles X 3)
Ink color	Cyan, magenta, yellow (Black is composite black.)
No. of pages printable	Approx. 45 pages (HQ mode, YMCK 7.5% duty per color pattern, continuous printing)
Weight	Approx. 62g (2.2 oz)

16. Detection functions

Paper out	Available
Presence of BJ cartridge	Available
Waste ink amount	Available
Paper width	None
Distinction of cartridge	Available
Ink out	None

17. Noise

Sound pressure level* Approx. 45 dB (A)

*:Conforming to sound pressure level ISO 9296

18. Environmental requirements

	Temperature	Humidity
During operation	5°C to 35°C (41°F to 95°F)	10% to 90%RH (no condensation)
Non operation	0°C to 35°C (32°F to 95°F)	5% to 95%RH (no condensation)

19. Power supply

Input voltage/Frequency	Power consumption	Stand-by status
AC 100 to 120V, 50/60 Hz	Approx. 20 W (Max.)	Approx. 2W (Max.)
AC 220 to 240V, 50/60 Hz	Approx. 20 W (Max.)	Approx. 2W (Max.)

20. External dimensions

360 mm W × 174 mm D × 160 mm H

21. Weight

Approx. 2.2kg (4.9 lbs) (excluding BJ cartridge and option)

2.2 Paper Specifications**2.2.1 Paper setting**

Media	Thickness Lever	Max. stacking height
Plain paper	Left	5 mm (LGL: 10 pages)
Bubble jet paper	Left	5 mm
Envelopes	Right	5* ¹
Transparencies	Left	20 pages* ¹
Back print Film	Left	10 pages* ¹
Glossy photo paper	Right	1 page* ¹
High gloss film	Left	1 page* ¹
High resolution paper	Left	5 mm
T-shirt transfers	Left	1 page* ¹
Fabric sheet	Right	1 page* ¹
Banner paper	Right	1 page* ²

*1:Each time a sheet is printed out, remove it from the tray. If the printed sheets stack immediately after they are delivered out, the ink, if not dried, may transfer to other sheets.

*2:Add one to page-length to the number of pages to be printed. The maximum length of banner data that can be printed at a time is up to six pages long. For example, when printing data of a length of 3 pages, use a length of paper equal to 4 pages.

2.2.2 Printing range

1) Plain paper and special media

The shaded portion in the diagram below shows the printable area and recommended printing area for paper and special media.

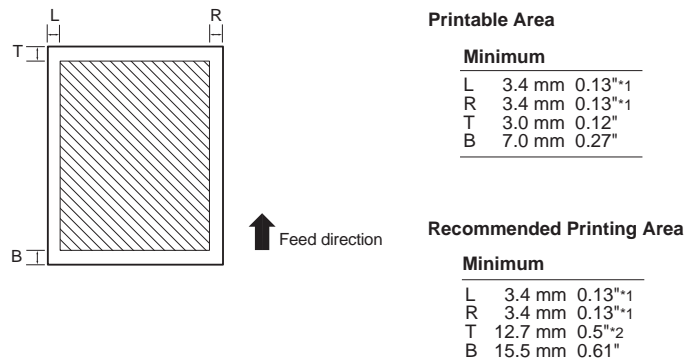

*1: LTR size: Land Rare 6.4 mm (0.25") minimum.

*2: When using Fine mode photo printing:
T is 25.4 mm (1.0") minimum.

Figure 2-6 Printing Area

2) Envelope

The shaded portion in the diagram below shows the printable area and recommended printing area for U.S. Commercial 10 envelopes (9.5 X 4.1 inches) and European DL-size envelopes (229 X 110 mm).

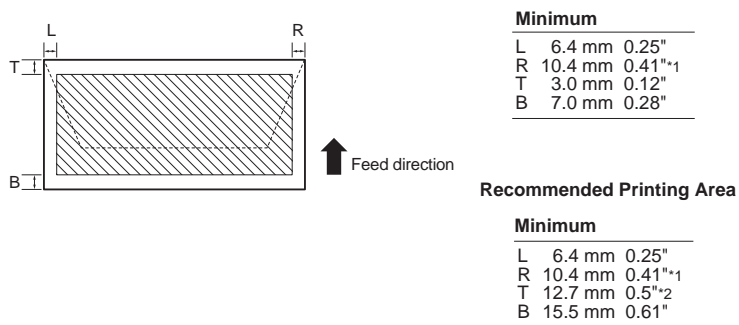

*1: For Commercial number 10 envelopes, 31.4mm (1.2").

*2: When using Fine mode photo printing:
T is 25.4 mm (1.0") minimum.

Figure 2-7 Printing Area (Envelope)

3) Banner paper

The shaded portion in the diagram below shows the printable area and recommended printing area.

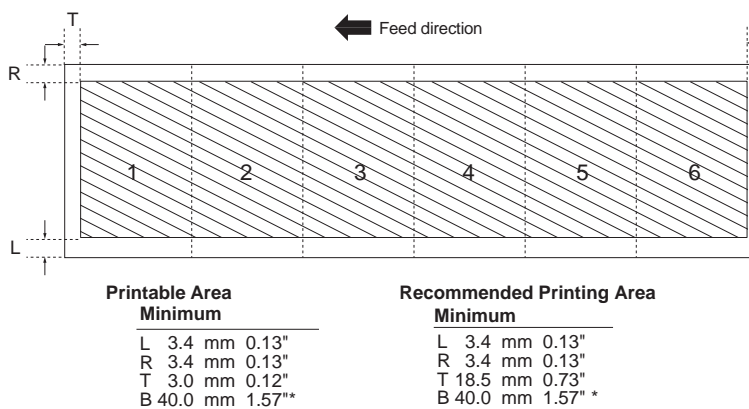

*: When printing 6 pages.

Figure 2-8 Printing Area (Banner Paper)

2.3 Interface Specifications

The parallel interface sends 8 bits (one byte) of data at a time and is transistor-transistor-logic (TTL) compatible.

The interface cable must be made of American Wire Gauge (AWG) No. 28 or larger. The maximum length of the twisted-pair shielded cable must be 2.0 m (approximately 6.6 feet).

1) Interface Type

IEEE1284 compatible parallel interface

2) Data transfer

8-bit parallel interface

3) Signal voltage levels

Low: 0.0 V to +0.8 V

High: +2.4 V to +5.0 V

4) Input/ output

Each signal pulled up with +5V.

5) Interface cable

Type: Twisted-pair shielded cable

Material: AWG#28 or larger

Length: Up to 2.0 m (6.6 feet)

6) Interface connectors

On printer: Amphenol 57-40360 (or equivalent)

On cable: Amphenol 57-30360 (or equivalent)

7) Input/ output signals and pin layout

Compatible mode

No.	Signal	I/O	No.	Signal	I/O
1	STROBE	IN	19	STROBE-RET ¹	...
2	DATA1	IN	20	DATA1-RET	...
3	DATA2	IN	21	DATA2-RET	...
4	DATA3	IN	22	DATA3-RET	...
5	DATA4	IN	23	DATA4-RET	...
6	DATA5	IN	24	DATA5-RET	...
7	DATA6	IN	25	DATA6-RET	...
8	DATA7	IN	26	DATA7-RET	...
9	DATA8	IN	27	DATA8-RET	...
10	ACKNLG	OUT	28	ACKNLG-RET	...
11	BUSY	OUT	29	BUSY-RET	...
12	P.E.	OUT	30	P.E.-RET	...
13	SELECT	OUT	31	INIT	IN
14	AUTO FEED XT ⁴	IN	32	ERROR	OUT
15	N.C. ²	...	33	GND	...
16	INIT-RET ¹	...	34	N.C. ²	...
17	GND	...	35	+5.0V ⁴	...
18	+5.0V ³	...	36	SELECT IN ⁵	IN

*1: All-RETs are connected to GND.

*2: N.C. means no connection.

*3: The level is connected with +5.0V through 390Ω resistor.

*4: The level is connected with +5.0V through 3.3kΩ resistor.

*5: These signals are effective only in LQ printer control mode.

Nibble mode

No.	Signal	I/O	No.	Signal	I/O
1	HostClk	IN	19	Signal Gnd	...
2	DATA1	IN/OUT	20	Signal Gnd	...
3	DATA2	IN/OUT	21	Signal Gnd	...
4	DATA3	IN/OUT	22	Signal Gnd	...
5	DATA4	IN/OUT	23	Signal Gnd	...
6	DATA5	IN/OUT	24	Signal Gnd	...
7	DATA6	IN/OUT	25	Signal Gnd	...
8	DATA7	IN/OUT	26	Signal Gnd	...
9	DATA8	IN/OUT	27	Signal Gnd	...
10	<u>Ptr Clk</u>	OUT	28	Signal Gnd	...
11	Ptr Busy	OUT	29	Signal Gnd	...
12	Ack Data Req	OUT	30	Signal Gnd	...
13	Xflag	OUT	31	<u>INIT</u>	IN
14	Host Busy	IN	32	<u>DataAvail</u>	OUT
15	Not Defined	...	33	Not Defined	...
16	INIT -RET ^{*1}	...	34	Not Defined	...
17	F.G.	...	35	<u>Not Defined</u>	...
18	Vcc	...	36	<u>1284 Active</u>	IN

*1: All-RETs are connected to GND.

8) Input/ output signals:**Compatible Mode****STROBE [Input]**

This signal is used to read DATA1 to DATA8. The signal becomes valid after BUSY signal goes Low and the printer outputs an ACKNLG signal. The host computer does not send the next signal until it receives ACKNLG signal. It is normally High; after it goes Low, the printer receives data. When the signal remains Low, the printer does not operate until it goes High.

DATA1 to 8 [Input]

The printer receives data with the STROBE signal. The state of each bit of the signal must be maintained for at least 0.5 μ s from the rising edge of the STROBE signal.

ACKNLG [Output]

This signal is a response signal to the STROBE signal. The host computer does not send the next STROBE signal until this signal is sent. When the power is turned on or the BUSY signal goes Low for the input of the INIT signal, this signal is sent regardless of the STROBE signal.

BUSY [Output]

When this signal is High, the printer is BUSY; when Low, the printer is READY. The signal goes High when data is received, when the printer is offline, or when an error occurs (paper-out, paper jam).

P.E. [Output]

When the printer cannot feed paper, this signal goes High. Then BUSY signal goes High and the SELECT and FAULT signals go Low. The signal goes Low when the paper is set and the printer goes online. FAULT and SELECT signals then go High from Low. If paper is not ejected (paper jam) by executing paper eject command, this signal and BUSY signal go High, and SELECT and FAULT go Low. In this case, the signals do not change even if the paper is ejected.

SELECT [Output]

The printer is selected when this signal is High. The printer is deselected when this signal is Low. This signal goes Low when the printer is offline or when an error occurs (paper-out, paper jam, head error, etc.).

AUTO FEED XT [Input]

Not used.

INIT [Input]

INIT from the system resets the printer to its initial power-on state. In BJ mode, the BUSY signal goes High, and any received data is printed. In LQ mode, the BUSY signal goes High, and the print buffer is cleared. When INIT signal goes Low, it resets the printer to the power-on default state.

FAULT [Output]

This signal goes Low when the printer is in an error state (paper-out, paper jam, etc.).

SELECT IN [Input]

Not used.

Nibble Mode**Host Clk [Input]**

The STROBE signal is to read DATA 1 to DATA 8.

Negotiation phase:

Trigger signal to send the protocol confirmation to the printer.

DATA 1-8 [Input]

The printer receives data with the Host Clk signal.

The state of each bit of this signal must be maintained for at least 0.5 μ s from the rising edge of the Host Clk signal.

Ptr Clk [Output]

Reverse data transmission phase:

The printer requests the host computer to read the data by making the Ptr Clk signal Low. After finishing reading, the host computer notifies peripheral equipment of completion of data receiving by making the Host Busy signal High.

Ptr Busy [Output]

Reverse data transmission phase:

Indicates bit 3 and bit 7 of the transmission data.

Ack Data Req [Output]

- Reverse data transmission phase:

Indicates bit 2 and bit 6 of the transmission data.

- Negotiation phase:

Trigger signal to inform the host computer of the printer's condition (Whether it supports nibble mode or not, whether there is reverse transmission data or not).

Xflag [Output]

- Reverse data transmission phase:

Indicates bit 1 and bit 5 of the transmission data.

- Negotiation phase:

Informs the host computer whether printer supports nibble mode or not, synchronizing with the falling edge of the Ack data Req signal. "Low" means that it supports nibble mode.

Host Busy [Input]

- Reverse data transmission phase:
Indicates that the host computer is ready to receive the data from the printer by making the Host Busy signal Low. After that, it goes High in synchronizing with Low pulse of Ptr Clk signal to verify receiving data.
- Reverse idle phase:
The Host Busy signal goes High in response to the Low pulse of the Ptr Clk signal, and enters the reverse data transmission phase again.

INIT [Input]

When this signal becomes Low, the printer's state becomes BUSY. When the signal changes from Low to High, it resets the printer control system to the initial state. This signal is normally High and the pulse width must be at least 0.5 μ s at the printer side.

After initializing, the printer enters the compatible mode.

DataAvail [Output]

- Reverse data transmission phase:
Indicates bit 0 and bit 4 of the transmission data.
- Negotiation phase:
Informs the host computer if there is reverse transmission data or not in synchronizing with the falling edge of the Ack Data Req signal. "L" means that there is reverse transmission data.

1284 Active [Input]

This signal confirms that the printer is a 1284 compatible device when 1284 Active signal goes High and Host Busy signal goes Low. It goes Low with the termination phase.

9) Timing

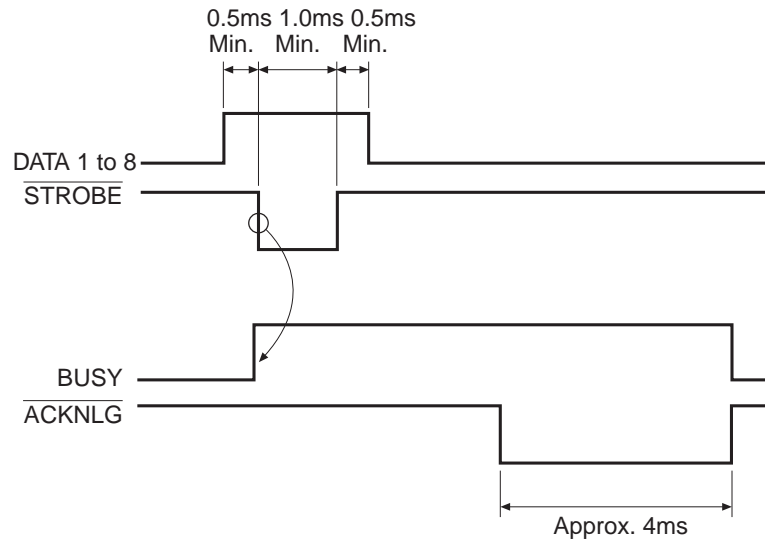

Figure 2-9 Timing Chart (Compatible Mode)

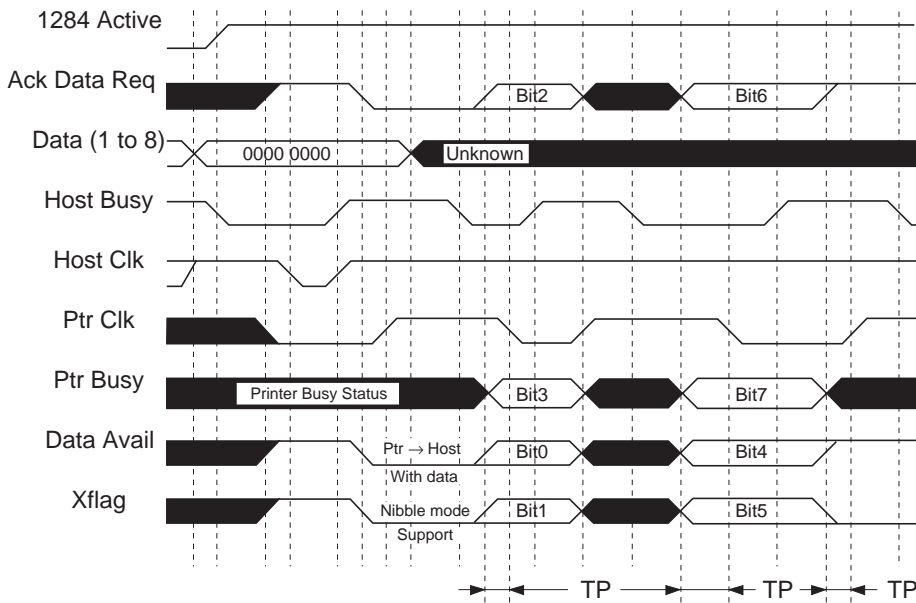

Figure 2-10 Timing Chart (Nibble Mode)

This page intentionally left blank



Part 3

OPERATING INSTRUCTIONS

Page	
3 - 1	1. PRINTER SETUP
3 - 1	1.1 Equipment Check
3 - 2	1.2 Printer Dimensions
3 - 3	1.3 Setup Procedure
3 - 6	1.4 Turning the Printer On/Off
3 - 7	1.5 Paper Settings
3 - 7	1.6 Banner Printing
3 - 8	1.7 Name of the Parts and Their Functions
3 -10	2. PRINTER SERVICING FUNCTIONS
3 -10	2.1 Error Indications
3 -11	2.2 Cleaning the BJ Cartridge
3 -11	2.3 Self-Test Printout
3 -13	2.4 EEPROM Reset

1. PRINTER SETUP

1.1 Equipment Check

After unpacking the printer, make sure the items below are included:

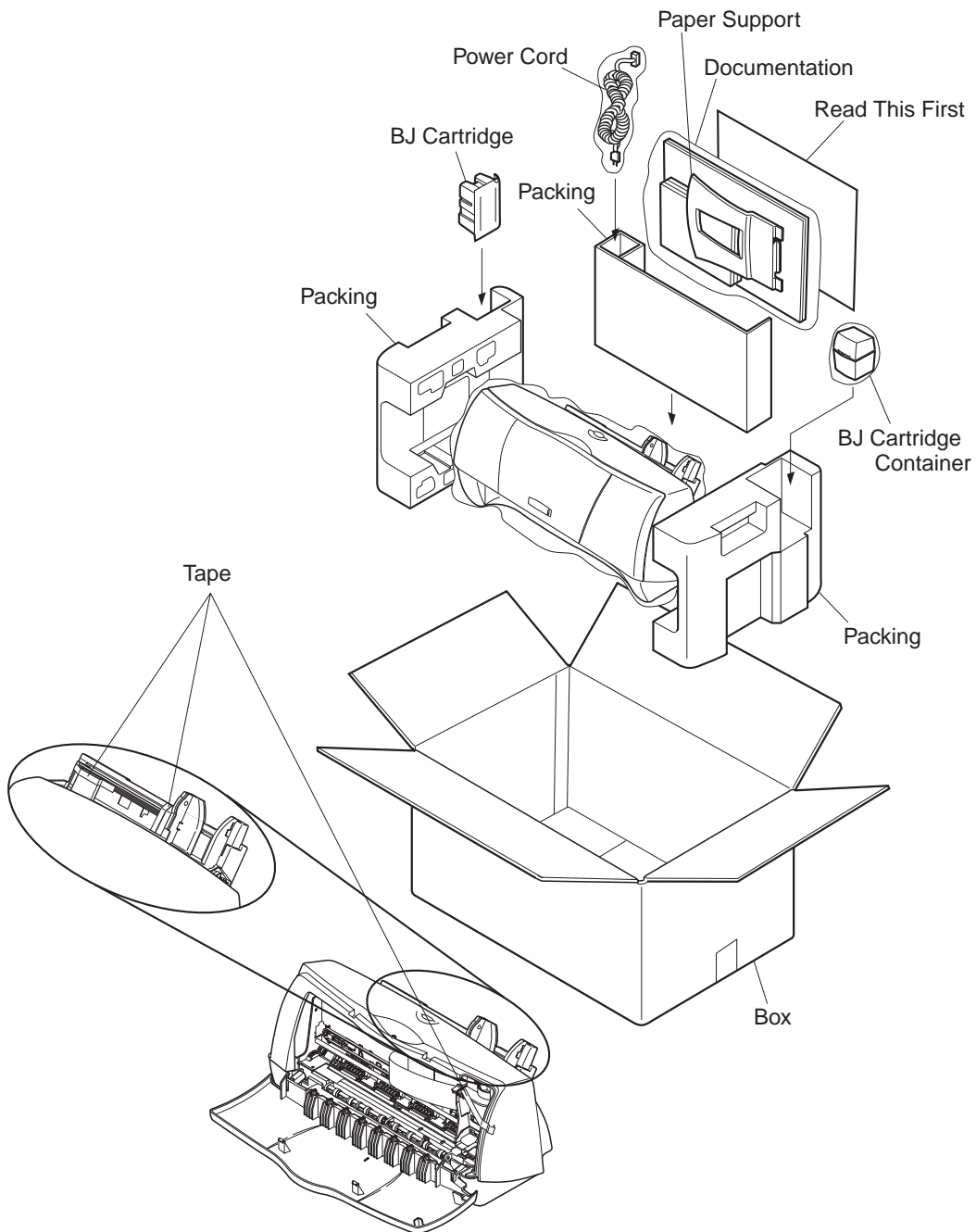

Figure 3-1 Packaging

1.2 Printer Dimensions

The printer's dimensions are shown below. Allow enough space for the printer to be used with ease.

For banner printing leave a space about the size of two A4-size papers in front of the printer. Also allow enough space at the back of the printer to set the banner paper.

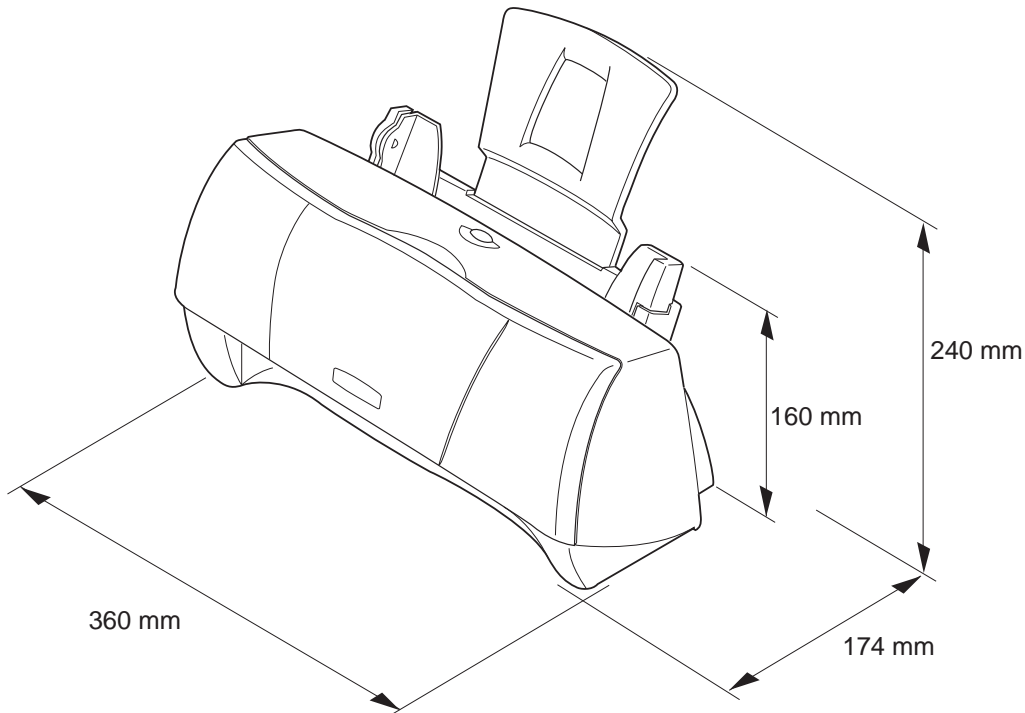

Figure 3-2 Printer Dimensions



-
- Do not place the printer in excessive heat or humidity.
 - Operate the printer under the following conditions:
 - Ambient temperature: 5°C to 35°C
 - Relative humidity: 10% to 90% (no condensation)
 - Do not place the printer in direct sunlight.
 - Do not place the printer near a device containing a magnet or generating a magnetic field.
 - Place the printer on a level and stable surface.
 - Do not place the printer in areas subject to vibration.
 - Keep the printer clean.
 - When moving the printer, hold both ends.
-

1.3 Setup Procedure

Set up the printer as follows.

1.3.1 Connecting the interface cable

- 1) Make sure that the printer's power cord is disconnected and the computer's power is turned off.
- 2) Connect one end of the parallel interface cable to the parallel interface connector on the back of the printer.
After connecting the cable, fasten the locking arms to secure it.
- 3) Connect the other end of the interface cable to the parallel interface connector on the computer.

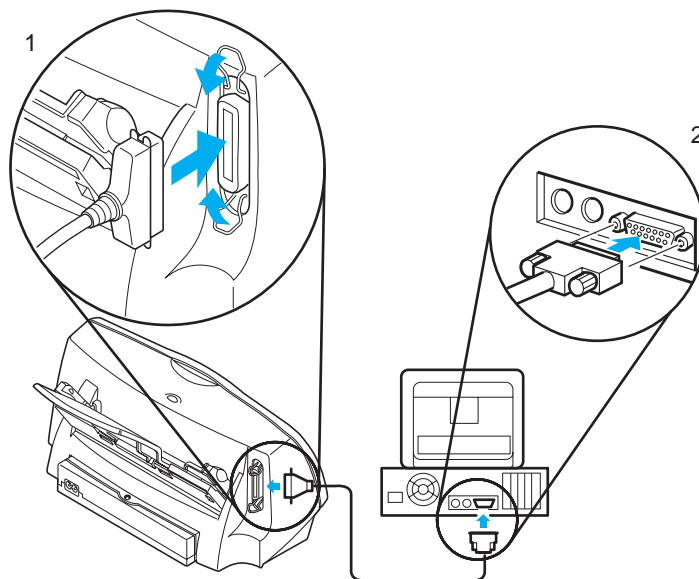

Figure 3-3 Connecting the Interface Cable

1.3.2 Turning on the printer

The printer turns on when the AC plug is plugged in.

Before turning on the printer, first turn on the computer and any other peripheral equipment. When turned on, the printer executes initializing operations. Finally, the carriage stops at the cartridge replacement position.

1.3.3 Installing the cartridge

Three types of cartridges can be installed in the printer: two color BJ cartridges and Black BJ cartridge.

1) Removing the BJ cartridge protectors

Take out the BJ cartridge from the package, then remove the cap protecting the nozzles and gently peel off the protective tape as shown in the figure.

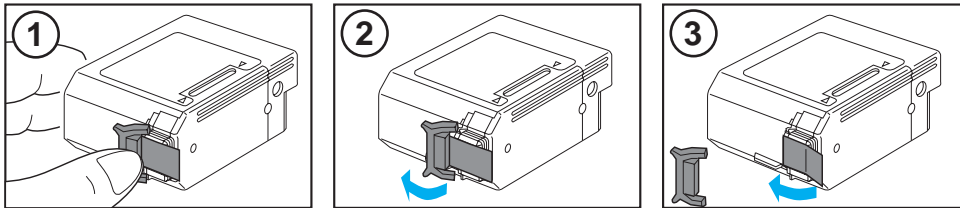

Figure 3-4 Removing the BJ Cartridge Protectors



Do not unpack the BJ cartridge until it is ready to be used.

Do not reuse the cap and tape, as doing so can clog the nozzles or mix the ink colors.

Do not touch the nozzles when removing the tape. Scratching the head face and ink contamination may result in poor printing.

Never touch or wipe the nozzles with tissue paper, etc. to prevent them from clogging.

To prevent foreign matter or dried ink from clogging the nozzles, install the BJ cartridge immediately in the printer or in the cartridge container after removing the cap and peeling off the tape.

Clogged nozzles can cause white streaks across printed area. If this problem persists even after the ink cartridge is cleaned by the printer, replace the BJ cartridge.

Do not shake the BJ cartridge after removing the cap and tape, as ink may leak from the cartridge.

BJ cartridges cannot be disassembled, reassembled, or washed.

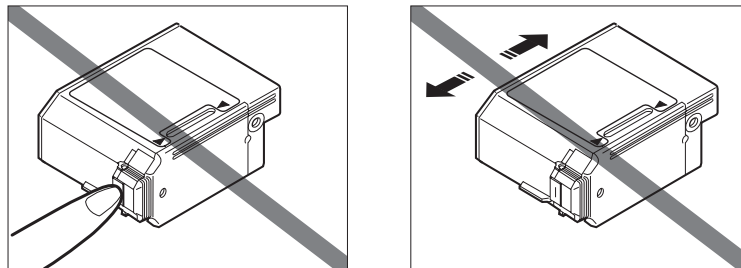

Figure 3-5 BJ Cartridge Handling Precautions

2) Installing the cartridge

Open the printer's front cover and flip up the cartridge lock lever. Attach the BJ cartridge to the carriage and push down the cartridge lock lever to lock the BJ cartridge in place.

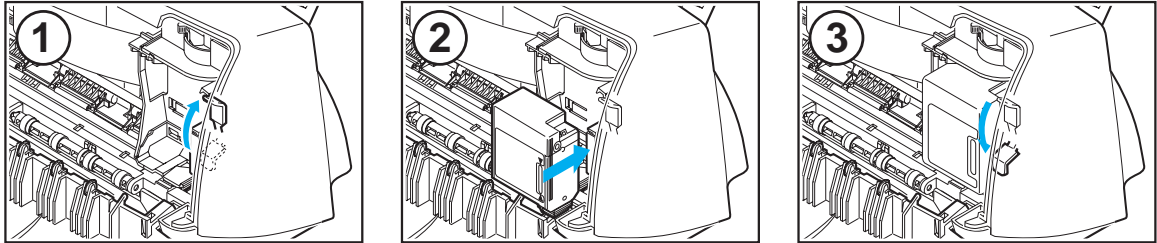

Figure 3-6 Cartridge Installation



There are four types of BJ cartridges that can be installed in the printer: BC-01, BC-02, BC-05 and BC-06 photo. To ensure optimum printer performance, use the BC-02, BC-05 or BC-06 photo. It is not recommended to use the BC-01 as they may cause poor print quality. Using the BC-01 will not damage the printer or the cartridge.

1.3.4 BJ cartridge container

A BJ cartridge container for storing the BJ cartridge is packed with the printer. Always store an unused BJ cartridge in the BJ cartridge container. The box can store one BJ cartridge only.

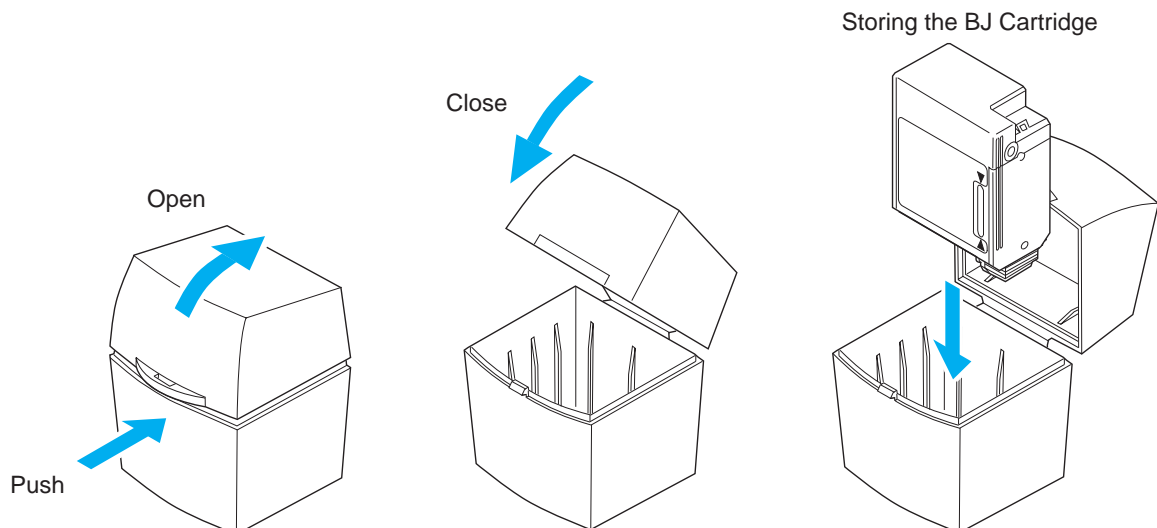

Figure 3-7 BJ Cartridge Container

1.4 Turning the Printer On/Off

1.4.1 Turning the printer on

Connect the power cord to a power source to turn on the printer, and initializing operations are executed.

1.4.2 Turning the printer off

Unplug the power cord from the power source to turn off the printer. When unplugging the power cord, wait at least one minute after completing an operation such as printing, feeding paper, cleaning the print head, etc.



Never unplug the power cord less than one minute after completing an operation. Otherwise, the BJ cartridge will not be capped. In such case, ink may leak or dry out in the nozzle.

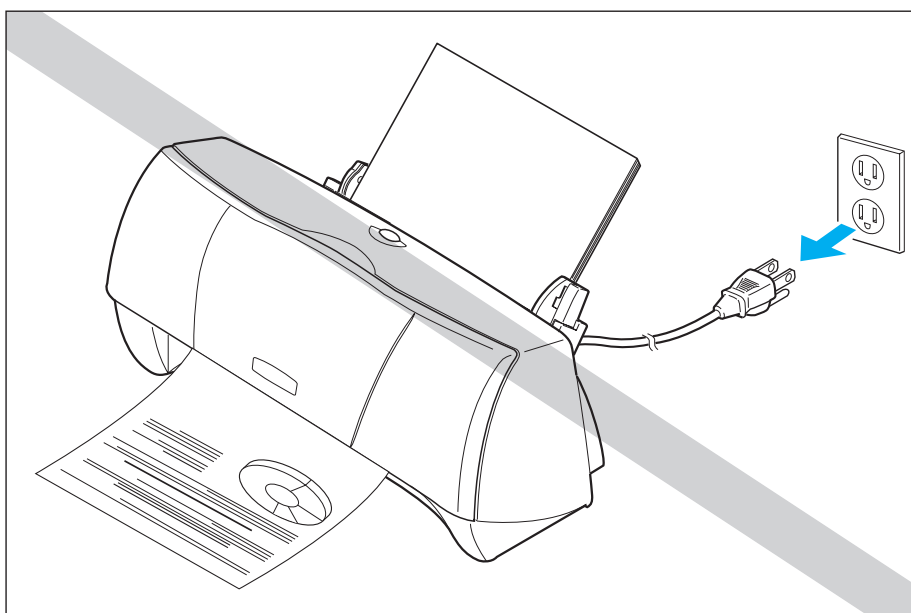

Figure 3-8 Never unplug the power cord less than one minute after completing an operation

1.5 Paper Settings

For optimum printing, the printer has various paper settings to suit various types of paper. Set the thickness lever before loading the paper.

TABLE 3-1 QUICK REFERENCE FOR SETTING

Media	Thickness Lever	Flap Position	Max. stacking height
Plain paper	Left	Flat	5 mm (LGL:pages)
Bubble jet paper	Left	Flat	5 mm
Envelopes	Right	Flat	5
Transparencies	Left	Flat	20 pages
Back Print Film	Left	Flat	10 pages
Glossy Photo paper	Left	Upright	1 page
High gloss film	Left	Flat	1 page
High resolution paper	Left	Upright	5 mm
T-shirt transfers	Left	Flat	1 page
Fabric Sheet	Right	Flat	1 page
Banner paper	Left	Upright	1 page

1.6 Banner Printing

When printing on banner paper, set the paper support and set the paper delivery flap to the upright position. To avoid misfeeding, put a light crease between the first and second page and set the first page in the sheet feeder. Place the rest of the banner paper behind the printer. Each top margin for banner printing is set at 0mm. However, to avoid printing on the platen, printing will start 3mm from the initial top margin. Set an extra sheet at the end in case the bottom edge is not printed on the last page.

Banner printing uses a large amount of ink. To avoid ink shortage, use of a new ink cartridge when printing banners is recommended.

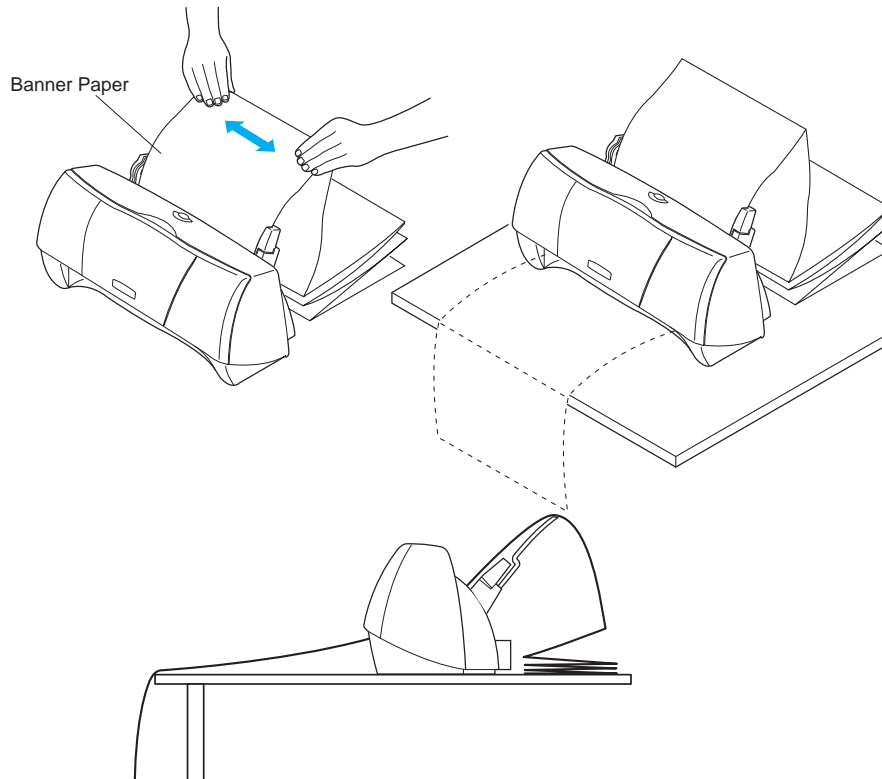

Figure 3-9 Banner Printing

1.7 Name of the Parts and Their Functions

The different parts of the printer and their functions are shown below.

Paper Support _____

Supports the stack of paper loaded in the cut sheet feeder.

Cut Sheet Feeder _____

Holds a stack of approximately 50 cut sheets (64g/m²) for automatic feeding.

Paper Guide _____

Aligns the cut sheets in the cut sheet feeder according to the paper size.

Front Cover _____

Open to install or remove the cartridge, set the paper thickness lever, or remove jammed paper.

RESUME button _____

This key has the following functions:
 -If you press and hold it for two seconds or more, the printer will reset and perform cleaning operation.
 -To recover an error, press once and release.
 -To start the nozzle check pattern, double click.

AC Adapter _____

Installed on the rear of the printer, the AC adapter supplies power from the power outlet to the printer.

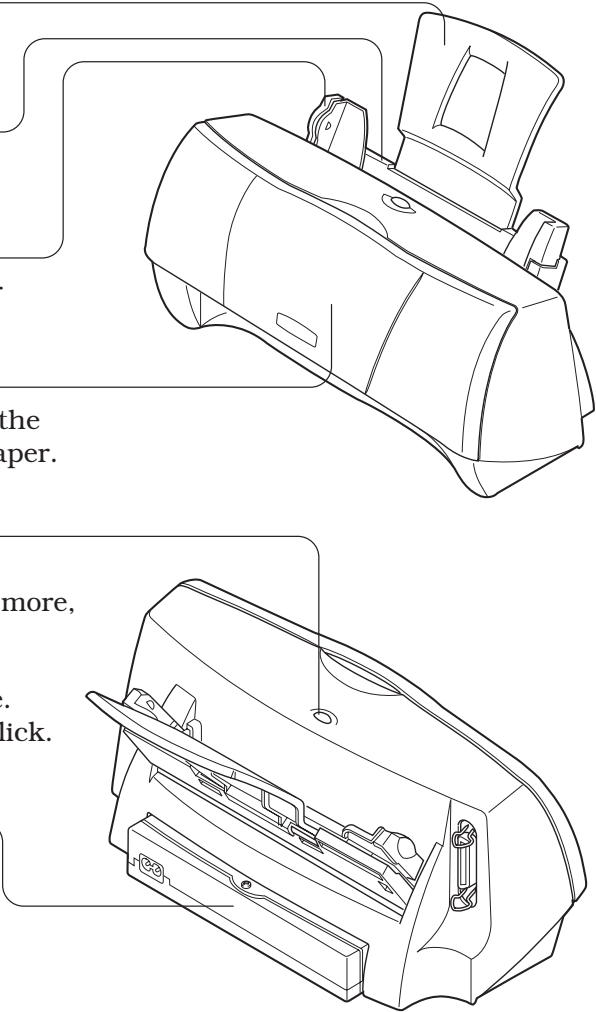

Figure 3-10 Name of the Parts and Their Functions (1)

Paper thickness lever —
Adjusts the gap between the print head and the paper. Set this lever according to the type of print media that you are using.

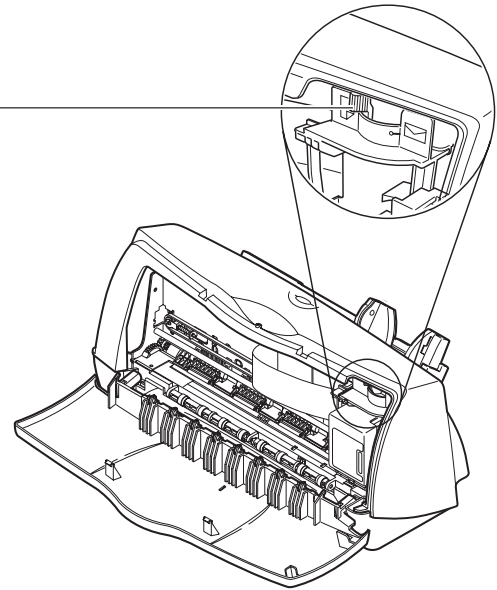

Figure 3-11 Name of the Parts and Their Functions (2)

Paper thickness lever

Adjusts the gap between the print head and paper according to the thickness of the paper. There are two settings: left for plain paper, high resolution paper, transparencies, back print film, glossy paper and high glossy film; and right for thick paper, envelopes, and banner paper.

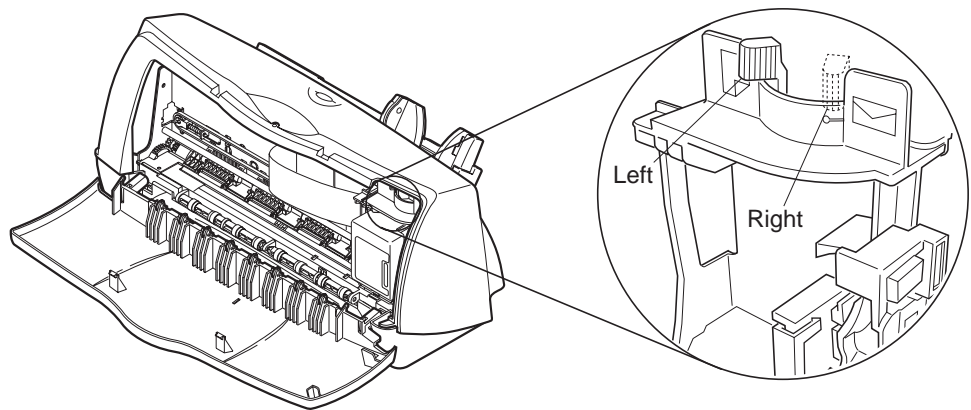

Figure 3-12 Paper Thickness Lever

2. PRINTER SERVICING FUNCTIONS

2.1 Error Indications

Errors will be displayed on the host computer monitor. (The host computer should be set to ECP or Nibble mode and use the BJ status monitor on Windows95/98.) Main error sentences are shown in the table below:

TABLE 3-2 ERROR INDICATIONS

Error condition	Error indication	Error code
[Recoverable by customers]		
Paper feed	The printer is out of paper.	...
Paper jam	A paper jam has occurred.	...
[Unrecoverable by customers]		
Home position error	An error that possibly requires a service call has occurred.	5000
Carriage control error	An error that possibly requires a service call has occurred.	5100
Printer temperature sensor error	An error that possibly requires a service call has occurred.	5400
No cartridge error	An error that possibly requires a service call has occurred.	5600
Waste ink full error	The used ink tank is full.	...
Purging operation error	An error that possibly requires a service call has occurred.	5C00

The errors listed in Table 3-2 are described below.

- **Recoverable errors by customers** (Correctable by removing the paper and pressing and holding down the *RESUME* button for over two seconds.).
 - 1) Paper pick-up error**
Occurs when the paper cannot be fed properly.
 - 2) Paper jam**
Occurs when the printed paper cannot be ejected.
- **Unrecoverable errors by customers** (Pull out the AC plug to turn off the power.)
 - 3) Home Position Error**
Displayed when the home position can not be detected.
 - 4) Carriage control error**
Occurs when the print position can not be corrected.
 - 5) Printer temperature sensor error**
Occurs when the temperature sensor's (TH1) reading on the control board is irregular.
 - 6) No cartridge error**
Occurs when the printer does not detect the BJ cartridge other than during BJ cartridge replacement.
 - 7) Waste ink full error**
Occurs when the "total waste ink amount" recorded by the EEPROM exceeds the prescribed limit.
 - 8) Purging operation error**
Occurs when the purging operation detection at the capping position is irregular.

2.2 Cleaning the BJ Cartridge

Press and hold the *RESUME* button for two seconds or more. The cleaning time is approximately 20 seconds.

After the cleaning, execute a test printout of the nozzle check pattern to check the print quality. (Double click the *RESUME* button.)

The printer cleans the BJ cartridge automatically at the following times:

- 1) When the printer is turned on for the first time. (When the AC plug is plugged in.)
- 2) After the BJ cartridge is replaced.
- 3) After the printer has been on for 72 hours following the last cartridge cleaning with a black BJ cartridge installed.
- 4) After printing a prescribed number of dots.

2.3 Self-Test Printout

This printer has built-in self-test functions which can be executed without any connection to a computer. There are two print modes available in self-test prints: the nozzle check pattern and the service test print.



All self-test prints require Letter or A4-size paper. Using smaller sized paper for a self-test print will result in parts of the printout being printed directly on the platen.

2.3.1 Nozzle check pattern

Double click the *RESUME* button while the AC plug is plugged in. After printing one page of the nozzle check pattern, the printer stops the test.

On the nozzle check pattern, a pattern using all nozzles, and the control ROM version are printed. In the event that print defects appear, perform a cleaning operation of the head. If print quality does not improve even after the cartridge is cleaned five times, replace the BJ cartridge.

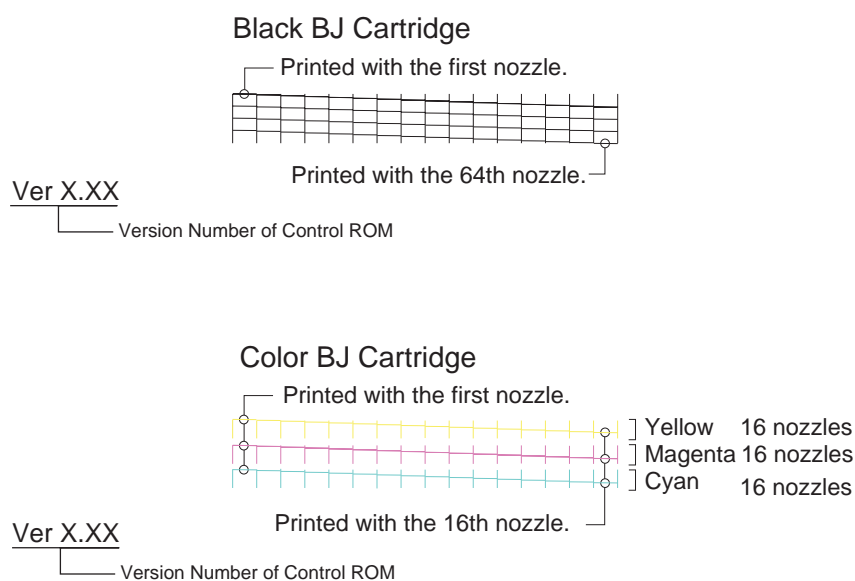

Figure 3-13 Nozzle Check Pattern

2.3.2 Service test print

On the service test print, the control ROM version, and EEPROM (IC8) data are printed, as shown below.

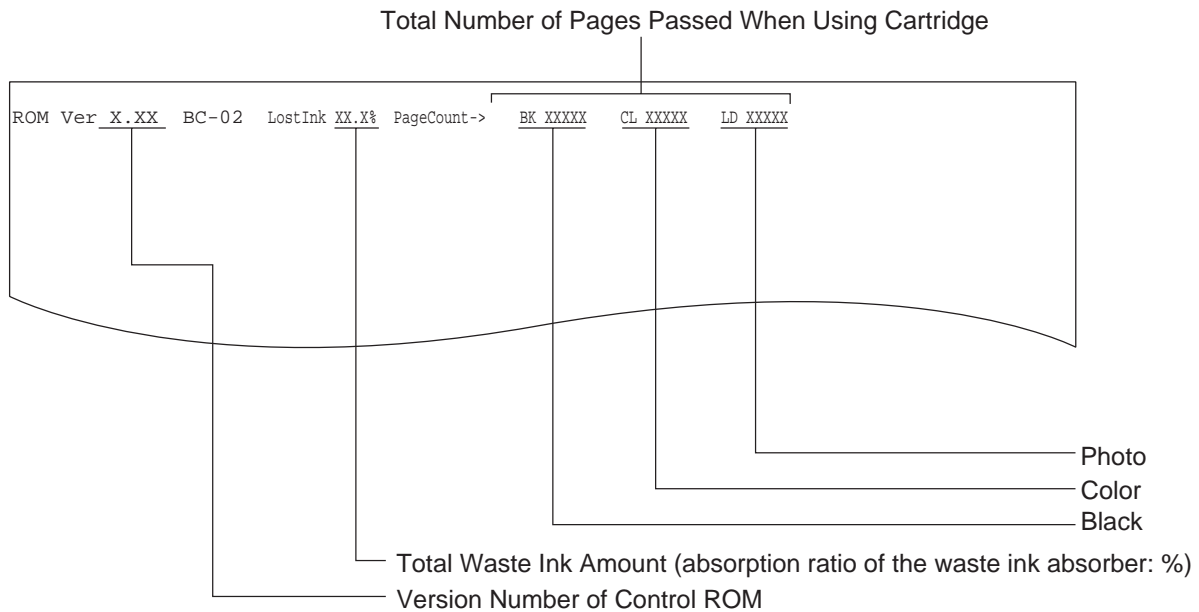

Figure 3-14 Service Test Print

The service test print is produced in the following procedure:

1. Without a cartridge installed, connect the plug of the AC adapter to the AC outlet while holding down the *RESUME* button.
2. Release the *RESUME* button. Press it down again within five seconds and release it. The carriage moves to the center, and stops.
3. Open the front cover and install the black BJ cartridge.
4. Close the front cover and press the *RESUME* button twice. The printer starts the service test printing.

2.4 EEPROM Reset

The EEPROM records various settings, the data on the total number of sheets printed, and the total waste ink absorption amount for the color and black ink cartridges respectively. The total number of sheets printed and the total waste ink absorption amount can serve as a reference for how much the printer has been used.

The EEPROM must be reset when the logic board or the bottom cover is replaced.

See *Part 5: 3.3 Logic Board and Bottom Cover Replacement Cautions (page 5-4)*, for details.

2.4.1 EEPROM Reset

"Waste ink full" is detected with the total waste ink absorption amount recorded in the EEPROM. When the ink absorber is replaced, the data on the total waste ink absorption amount in the EEPROM must be reset. Furthermore, when the logic board is replaced, the new logic board's EEPROM must be reset and the waste ink absorber must be also replaced at the same time. To reset the EEPROM, follow the procedure below.

1. Without the cartridge installed, connect the plug of the AC adapter to the AC outlet while holding down the *RESUME* button.
2. Release the *RESUME* button. Press it down again within five seconds and release it.
3. Hold down the *RESUME* button for two seconds or more and release it.
4. Set EEPROM by pressing the *RESUME* button as shown in the table below.

TABLE 3-3 DEFAULT SETTING WHEN RESETTING THE EEPROM

Operation	Contents of setting
Hold down for two seconds or more. Press once.	EEPROM reset & destination setting (Other than Japan)
Press twice. (Second time: within one sec. of first time)	Destination setting (Japan)* Destination setting (Others)* (* reference: Will not reset EEPROM)

5. To check this procedure, power off the printer first, then, after turning the printer on again, make a service test print. See *2.3.2 Service test print (page 3-12)*.



Be careful when performing the above operation as the EEPROM data cannot be recovered once it is reset.

2.4.2 Printing the EEPROM data

The following data recorded in the EEPROM can be printed on the service test print. See *2.3.2 Service test print (page 3-12)*.

- 1) Total number of sheets for black, color and photo ink cartridges, respectively.
- 2) Total waste ink absorption amount.



Resetting the EEPROM will permanently erase all data contained.

This page intentionally left blank



Part 4

TECHNICAL REFERENCE

Page	
4 - 1	1. OVERVIEW
4 - 1	1.1 Block Diagram
4 - 2	1.2 Printing Signal Flow
4 - 3	1.3 Print Drive
4 - 5	2. FIRMWARE
4 - 5	2.1 720 dpi Printing/Smoothing Feature
4 - 6	2.2 Printing Modes
4 - 7	2.3 Optimum Printing Direction Control
4 - 8	3. PRINTER MECHANICAL SYSTEM
4 - 8	3.1 Overview
4 -10	3.2 BJ Cartridge
4 -17	3.3 Purge Unit
4 -19	3.4 Carriage
4 -22	3.5 Paper Feed
4 -24	4. PRINTER ELECTRICAL SYSTEM
4 -24	4.1 Overview
4 -25	4.2 Logic Section
4 -28	5. SENSOR FUNCTIONS
4 -28	5.1 Pick-Up Roller Sensor
4 -28	5.2 Paper End Sensor
4 -28	5.3 Home Position Sensor (Purge Sensor)
4 -29	5.4 Temperature Sensor
4 -29	5.5 Waste Ink Amount Detection

1. OVERVIEW

1.1 Block Diagram

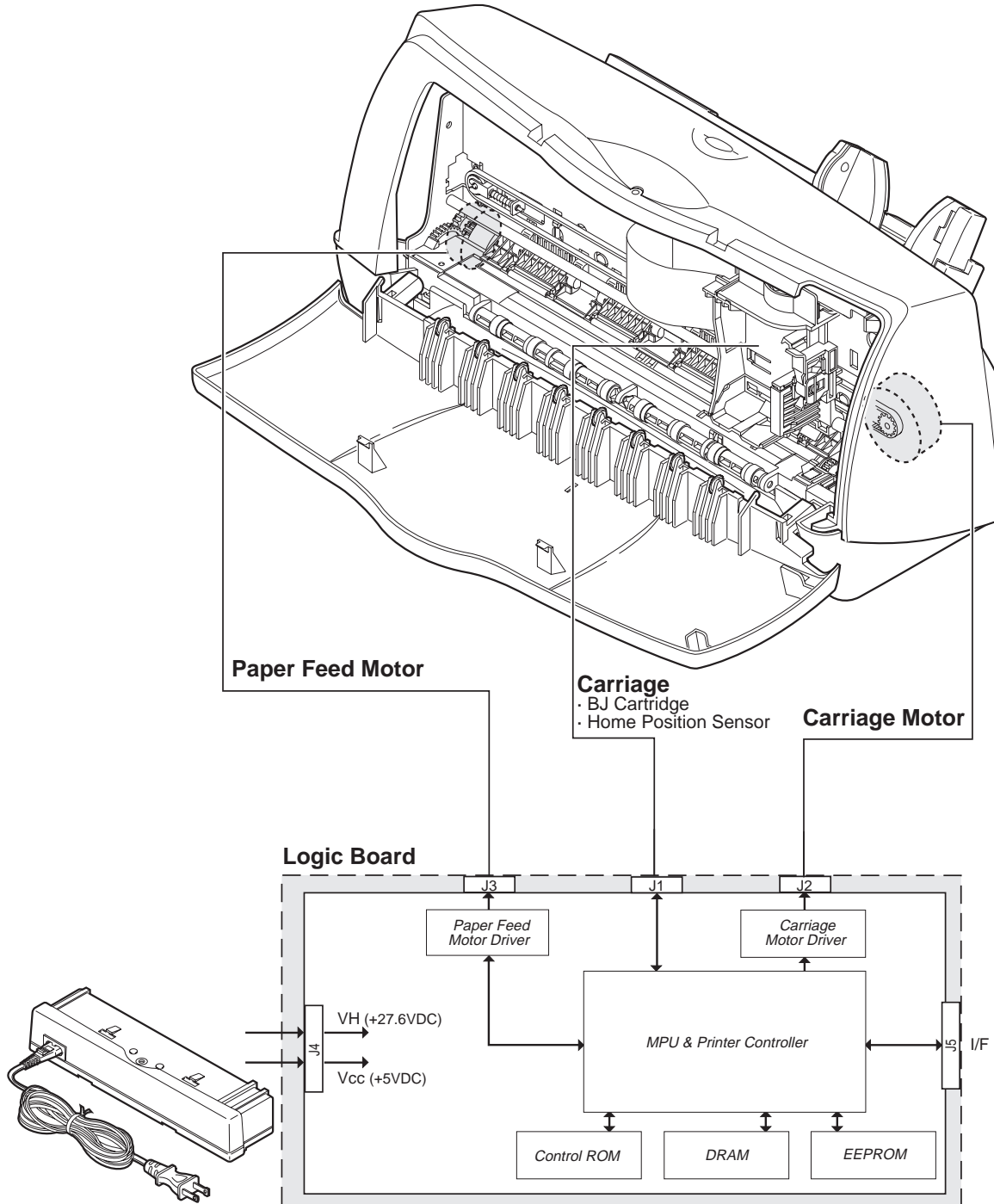

Figure 4-1 Block Diagram

1.2 Printing Signal Flow

The print signal flow from when the printer receives the print data to when printing is executed is described below.

- a) The print data, which include control signals, are output from the host computer, and are sent to the MPU & printer controller via an interface.
- b) The print data sent to the MPU & printer controller are then separated into control signals and bit image data. The control signals are processed into control commands based on the data stored inside the control ROM, and bit-mapped image data are organized inside the print buffer of the DRAM.
- c) The image data organized inside the print buffer are then moved to the MPU & printer controller, one line of each pass at a time.
- d) The image data moved to the MPU & printer controller are then converted to serial data, and are output to the BJ head as print signals. Inside the BJ head, the serial data are then converted into one column of parallel print data, thus allowing printing to be implemented.
- e) While performing check of the information (data) inside the control ROM, control of motor drivers, and detection of the BJ head and printer statuses, the MPU & printer controller works to control the entire print drive control system.

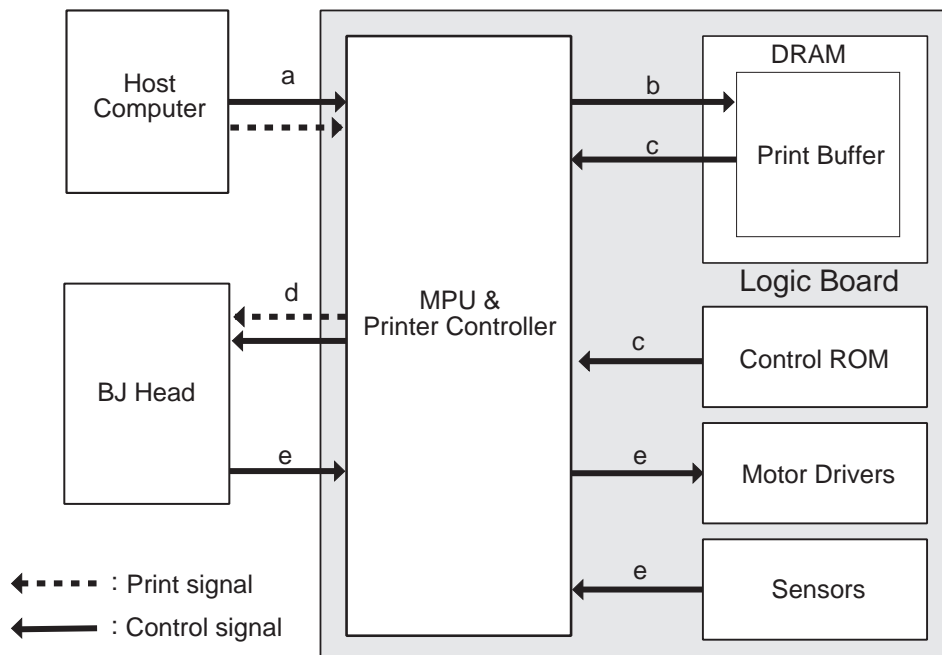

Figure 4-2 Printing Signal Flow

1.3 Print Drive

To eject ink from the head for printing, the printer controller generates control signals to the BJ head.

The control signals consist of the drive control signal for ejecting ink from the head's nozzles and the temperature control signal for adjusting the head's temperature so that the amount of ink ejected is uniform.

To achieve optimum printing, both these control signals are optimized by the printer controller and sent to the BJ head through the carriage ribbon cable.

The drive frequency varies depending on the printing mode and BJ cartridge type.

1.3.1 Printing drive control

a) Black BJ cartridge drive control

The driving control of 64 nozzles in the black BJ cartridge is executed by the matrix structure of 8 COM signals and 8 SEG signals. The COM signal connects the COM1 to COM8 circuits to the head drive power supply (VH) in order that the 64 nozzles are ready to print in units of eight nozzles. While the COM signal is connected to the head drive power supply, the SEG signal connects the SEG circuits (SEG1 to SEG8) for the even- and odd-numbered nozzles to the ground, and applies the heater voltage to the heater plate. The load on the AC adapter is reduced and ink charging delay is prevented by driving the head in steps.

The SEG signal has two pulses, pre-pulse and main pulse. The pre-pulse does not eject ink, but increases the head temperature to the appropriate value, and the main pulse ejects ink. The printer controls each pulse width to obtain the optimum print density according to the print speed and temperature.

b) Color BJ cartridge drive control

With exception of the following points, the head drive control of the color BJ cartridge is the same as that of the black BJ cartridge.

The nozzle configuration of color BJ cartridge is different from that of black BJ cartridge, and the COM 1 and 2 signals are used for driving the nozzle heaters for C, COM 4 and 5 signals for M and COM 6 and 7 for Y.

The color BJ cartridge has 16 nozzles each for Y, M, and C, whereas the black BJ cartridge has 64 nozzles for black only.

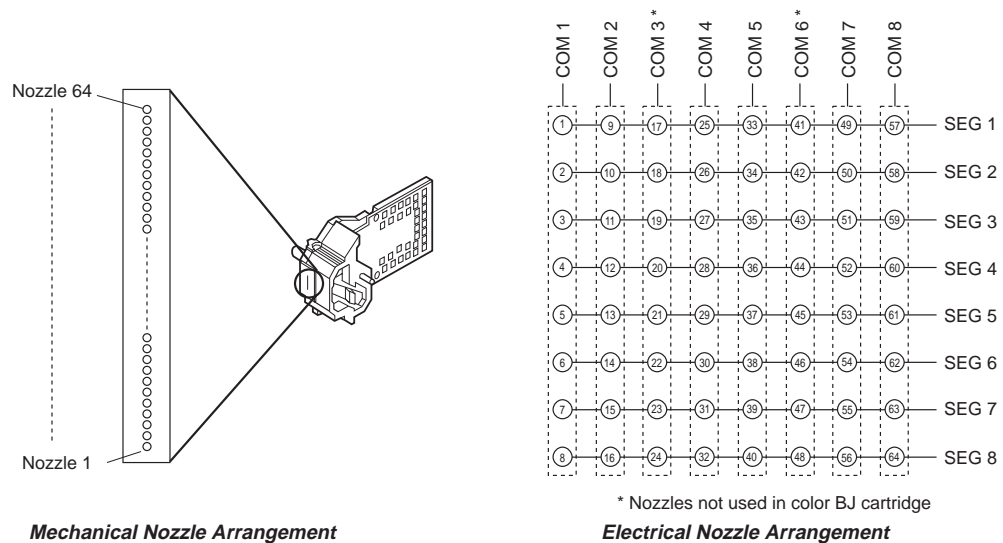
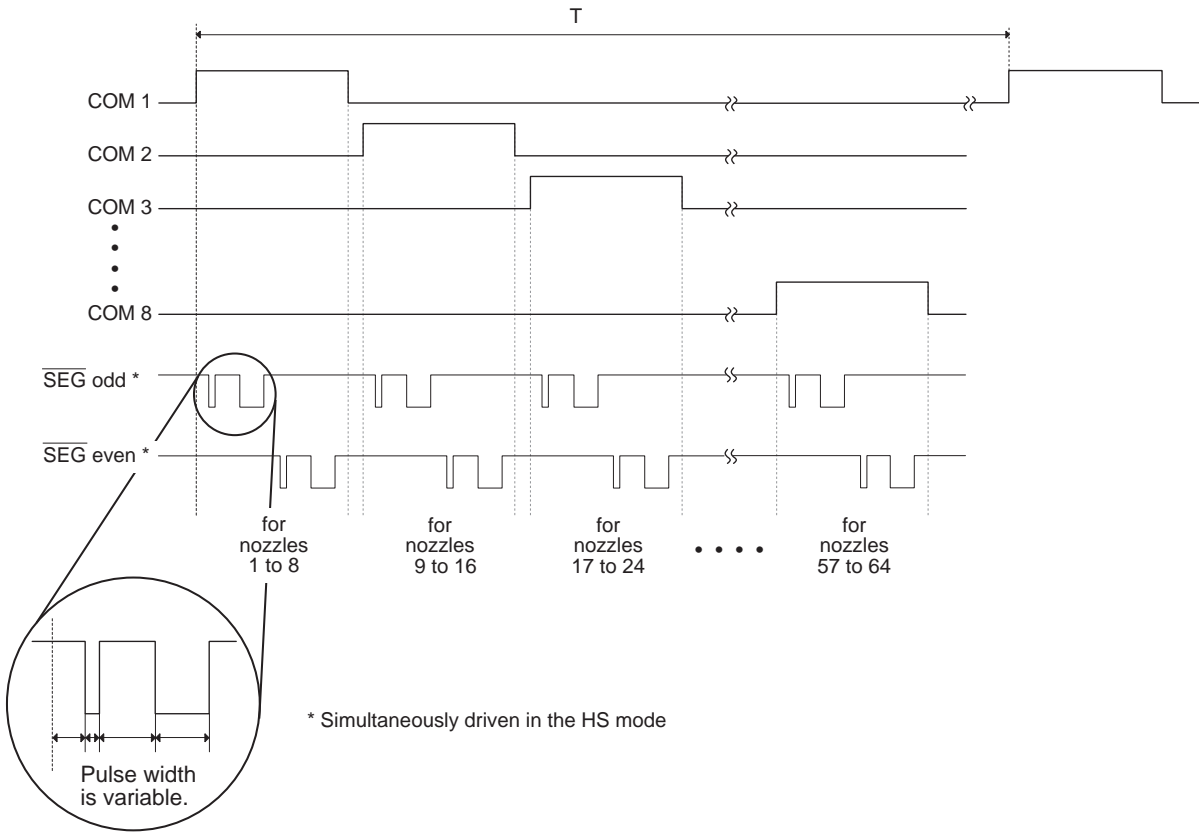

Figure 4-3 Nozzle Arrangement



"T" values are shown in the table below. Heater drive frequencies are in parentheses.

	Black BJ cartridge	Color BJ cartridge	Photo BJ cartridge
HS	112 μ s (8.93kHz)	112 μ s (8.93kHz)	—
HQ	136 μ s (7.35kHz)	136 μ s (7.35kHz)	—
720dpi/Smoothing	96 μ s (10.4kHz)	—	—
Photo	—	—	88 μ s (11.4kHz)

Figure 4-4 Printing Signals

2. FIRMWARE

2.1 720 dpi Printing/Smoothing Feature

This feature operates only with the black BJ cartridge.

2.1.1 Canon extension mode

In the Canon Extended mode, the printer driver creates 720 dpi data for the horizontal direction and sends it to the printer, resulting in high-quality printing. The printer driver smoothes the printed character's edges at 720 dpi along the horizontal direction. The 720 dpi data for the horizontal direction is sent to the printer and the edges are smoothed at a high resolution.

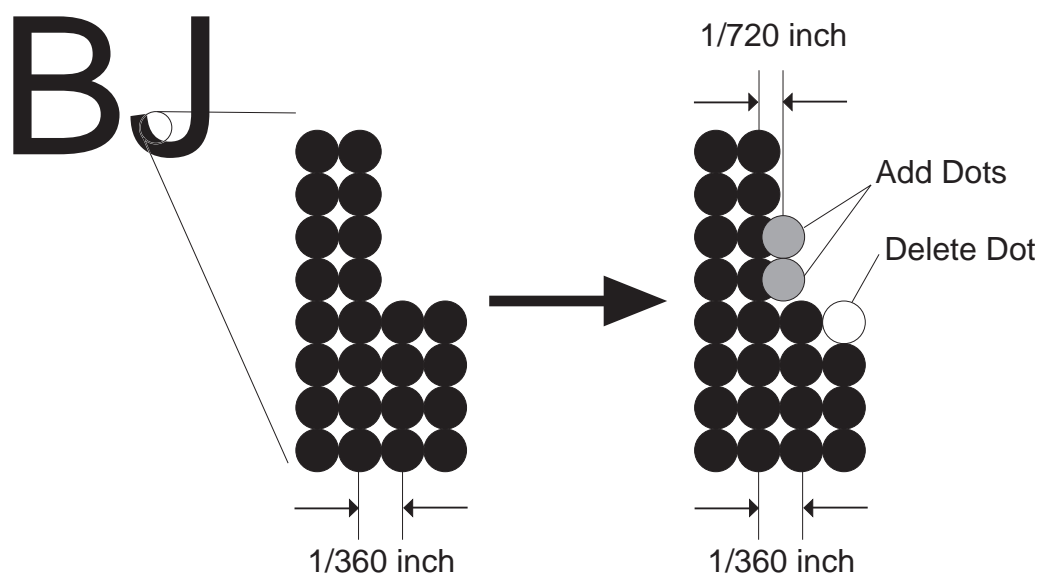

Figure 4-5 720 dpi Printing/Smoothing Feature

2.2 Printing Modes

2.2.1 Printing mode

Depending on the cartridge installed, the media, the printing mode, the resolution, the printing data, etc., the printer varies the carriage movement, bubble jet head driving frequency, etc., to attain high-quality printing without any bleeding or shifting in the printout.

The smoothing function is available only when using the black BJ cartridge. When the 720 dpi printing/smoothing feature is used, the carriage feed pitch is set to 1/720 inch. Although this slows down the carriage speed, the bubble jet head's driving frequency (heat frequency) is increased so that the overall printing throughput decreases little.

When monochrome printing is conducted using the color BJ cartridge, composite black is used as the color. Composite black is made from three colors of Y, M and C, and it is printed in 66.7% duty of each color, total approximately 200% duty. The boundary line is printed with 100% duty of each color, total 300% duty. This makes the black color look darker.

With the photo BJ cartridge installed, this printer prints pixels by dividing the pixel data into a maximum of 4-values (no printed, print 1 dot, print 2 dots, print 3 dots). This method enables the printer to achieve high degree gradation printing. When printing with 2 dots, the second dot is printed in the 720 dpi position. When printing with 3 dots, the second dot is printed in the 720 dpi position while the third dot is printed on top of the first dot. When monochrome printing using the photo BJ cartridge, printing is conducted at a maximum total (C/Y/M) of 400% duty, but the boundary lines are not emphasized.

The printing method for the respective printing modes are listed below.

TABLE 4-1 PRINTING MODES AND HEATING METHODS

With a Black BJ Cartridge

Printing Mode	Carriage Movement	Number of Nozzles	Heat Frequency [°]
Fine	4 passes	16 nozzles	7.35KHz [7.35KHz]
HQ (Smoothing OFF)	1 pass	64 nozzles	7.35KHz [7.35KHz]
HQ (Smoothing ON)	1 pass	64 nozzles	10.42KHz [5.21KHz]
HS	1 pass	64 nozzles	8.93KHz [8.93KHz]

With a Color BJ Cartridge

Printing Mode	Carriage Movement	Number of Nozzles	Heat Frequency [°]
Fine	2 passes	8 nozzles	7.35KHz [7.35KHz]
HQ	1 pass	16 nozzles	7.35KHz [7.35KHz]
HS	1 pass	16 nozzles	8.93KHz [8.93KHz]

With a Photo BJ Cartridge

Printing Mode	Carriage Movement	Number of Nozzles	Heat Frequency [°]
Photo	2 passes	8 nozzles	11.4KHz [5.7KHz]

* [°]: Carriage speed

2.3 Optimum Printing Direction Control

To prevent vertical misalignment of the printed characters, etc., when print data is printed continuously in the direction of the paper feeding direction, printing is executed with the carriage moving in only one direction.

However, when printing in the paper feeding direction is not continuous, since vertical misalignment is not so noticeable, the printing direction is alternated so that printing is also executed from the opposite carriage direction. This improves the throughput.

If four or more successive null rasters are detected in the lower (in the direction of paper ejection) 24 nozzles for the printing data in the printer buffer during single-pass printing, printing is executed up to the null raster. From the null raster onward, printing is executed from the opposite carriage direction. From the next raster onward, printing is executed from the same carriage direction until the direction changes again.

3. PRINTER MECHANICAL SYSTEM

3.1 Overview

This section explains the printer's mechanical components.

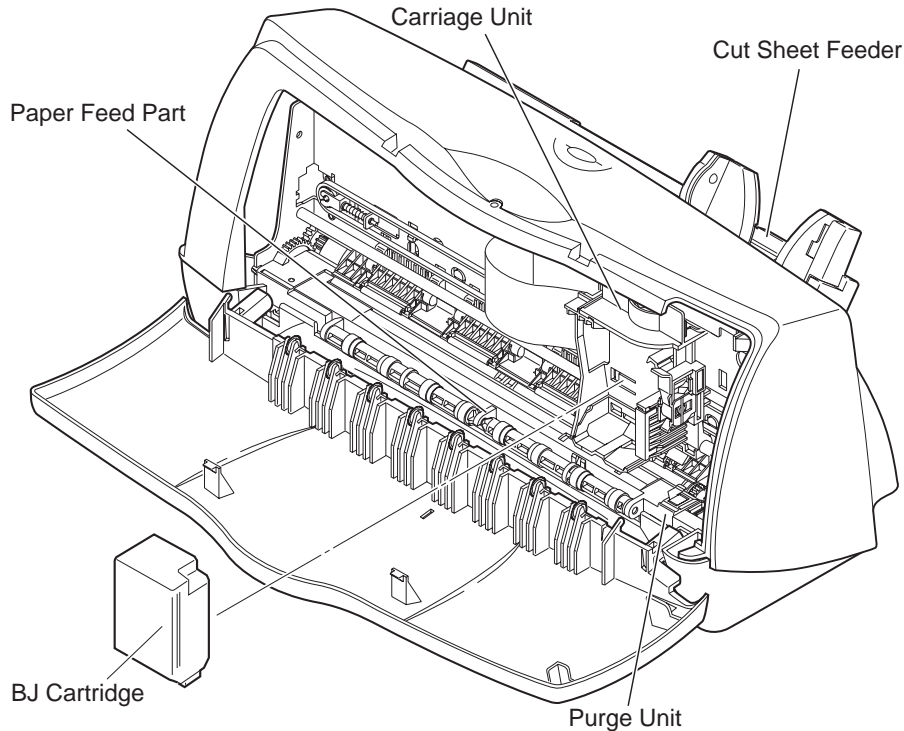

Figure 4-6 Printer's Mechanical Configuration

3.1.1 Mechanical components

1) BJ cartridge

The printer can use three types of BJ cartridges: black, color, and photo. The user installs the black, color, or photo BJ cartridge according to the required application. All these cartridges are ink-disposable.

2) Purge unit

Driven by the carriage motor, the purge unit helps to maintain high-quality printing by capping and wiping the BJ cartridge's bubble jet face. It ensures that the ink in the nozzles is ejected easily.

When the printer is not in use, the purge unit caps the BJ cartridge's nozzles for protection.

3) Carriage unit

Driven by the carriage motor, the carriage moves horizontally across the paper. Through the carriage ribbon cable, the printing signals from the logic board are transmitted to the BJ cartridge in the carriage.

By controlling the purge unit's slide lock pin, the carriage controls the engagement of the paper feed motor's drive power between the paper feed/purge unit and the sheet feeder.

4) Paper feed mechanism and sheet feeder

The built-in sheet feeder is driven by the paper feed motor. Plain paper as well as coated paper, transparencies, back print film, envelopes, etc., can be loaded and fed automatically into the paper feed mechanism.

Driven by the paper feed motor, the paper feed mechanism rotates the feed rollers to feed the paper vertically.

When printing transparencies and back print film, remove each sheet immediately after it is printed. This is to allow enough time for the ink to dry.

The paper ejection operation of this printer is performed using the *RESUME* button.

3.2 BJ Cartridge

3.2.1 Black BJ cartridge structure

The black BJ cartridge has a printing head equipped with 64 nozzles. The printing head and ink cartridge are built-in.

1) Side cover

This plastic cover is fixed to the cartridge body to prevent ink leaking from the ink sponge.

2) Ink sponge

This sponge is soaked with black ink. It is compressed and stored in the cartridge body.

3) Cartridge body

This is a plastic case which links the ink sponge with the bubble jet head unit via the ink filter.

4) Air Hole with Pressure Regulation Cap

As the ink is consumed, the pressure inside the cartridge decreases compared to the atmospheric pressure. This makes it more difficult for the ink to be supplied to the head. To prevent this, the ink cartridge has an air intake for maintaining a constant pressure inside the cartridge body.

5) Bubble jet head unit

As dictated by the printing signals received through the signal contact, ink is ejected through the 64 bubble jet nozzles.

6) Head cover

The plastic head cover protects the bubble jet head unit.

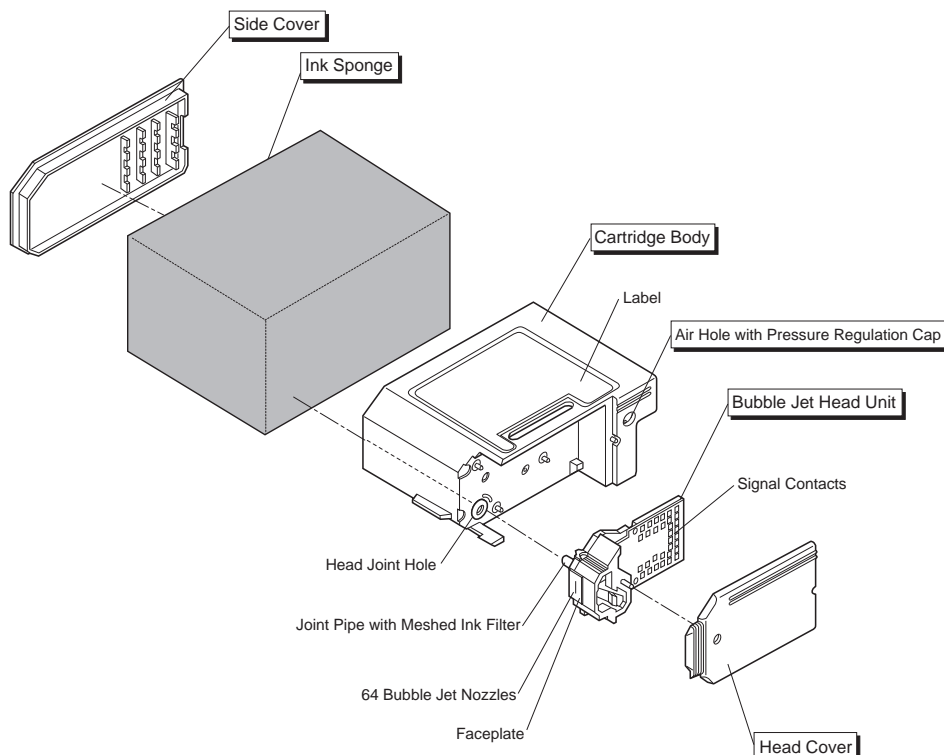

Figure 4-7 Black BJ Cartridge Structure

3.2.2 Color/Photo BJ cartridge structure

The color/photo BJ cartridge has a printing head equipped with 64 nozzles through which the three ink colors are ejected (16 nozzles each for yellow, magenta, and cyan). The printing head and ink cartridge are built-in.

1) Side cover

This plastic cover is fixed to the cartridge body to prevent ink leaking from the ink sponge.

2) Ink sponges

Each color ink (yellow, magenta, cyan) is soaked in its respective sponge. The yellow, magenta, and cyan ink sponges are compressed and stored in the cartridge body.

3) Cartridge body

This is a plastic case which links the ink sponge with the bubble jet head unit via the ink filter.

4) Air Hole with Pressure Regulation Caps

As the ink is consumed, the pressure inside the cartridge decreases compared to the atmospheric pressure. This makes it more difficult for the ink to be supplied to the head. To prevent this, the ink cartridge has an air intake for maintaining a constant pressure inside the cartridge body.

5) Bubble jet head unit

As dictated by the printing signals received through the signal contact, ink is ejected through the 48 bubble jet nozzles.

6) Head cover

The plastic head cover protects the bubble jet head unit.

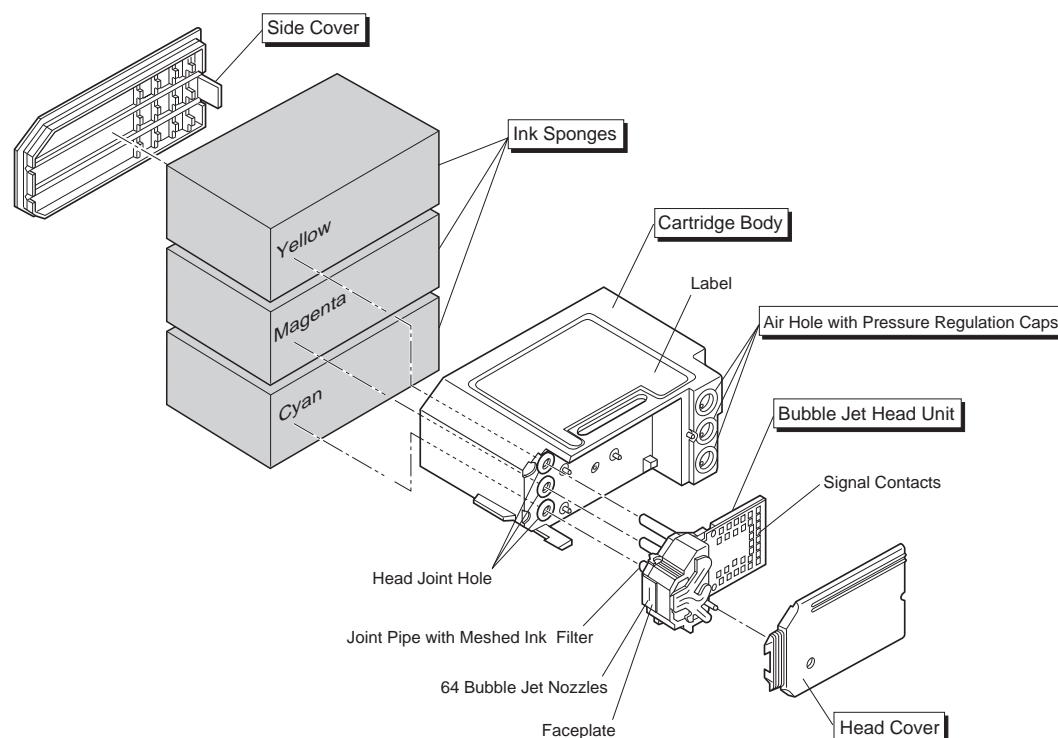

Figure 4-8 Color/Photo BJ Cartridge Structure

3.2.3 Bubble head unit structure

1) Bubble jet nozzles

The ink in the sponge passes through a mesh-type ink filter and flows to the bubble jet nozzles through the joint pipe.

When the head-driving current is supplied to the heater board, and multiple ink bubbles form. Eventually, only one ink bubble is formed. The head-driving current is turned off before the ink drop leaves the nozzle. The bubbling however continues with the residual heat and the ink drops are ejected from the nozzles.

After an ink drop is ejected, the nozzle is filled with ink supplied from the ink sponge.



The print head's heater board uses semiconductor technology with the heater and circuitry built on a silicon plate. This silicon plate, which contains various electrical circuitry, is attached to an aluminum base. The plastic cover, which is shaped to fit the nozzles, is also attached.

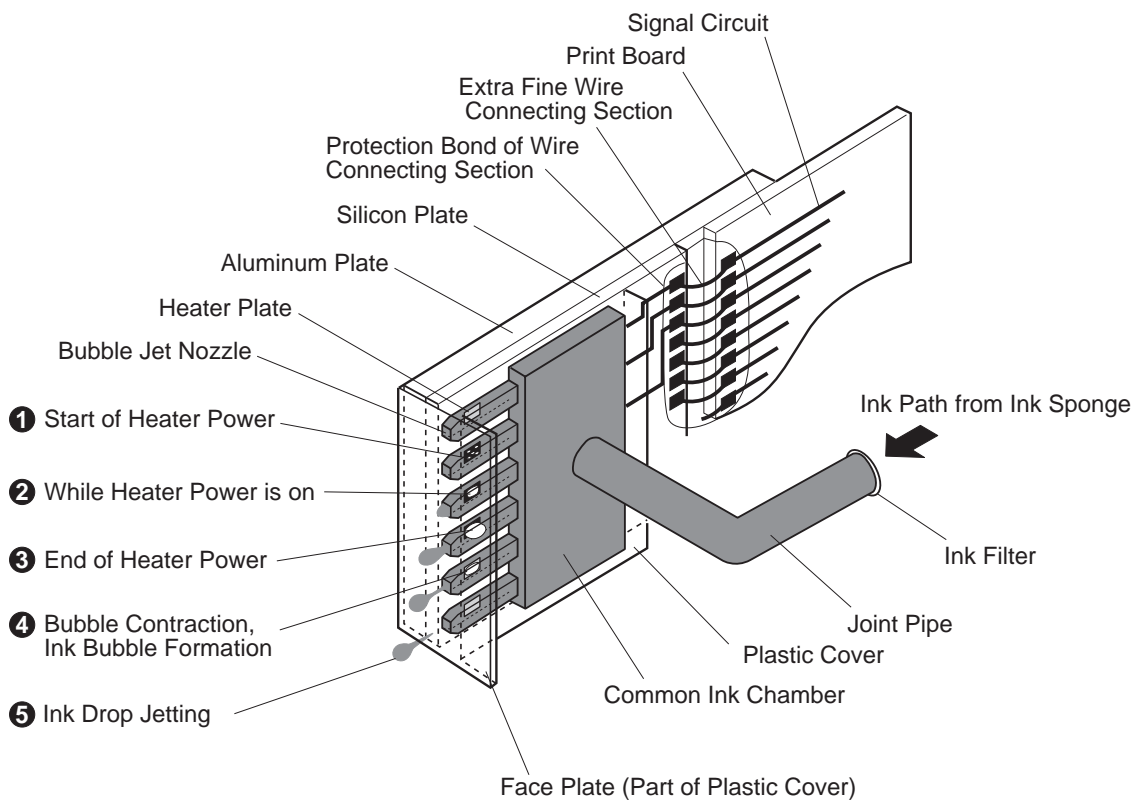

Figure 4-9 Bubble Jet Nozzles (Partial View)

2) Nozzle arrangement

The bubble jet nozzles are arranged 1/360 inch apart in a vertical array. The black BJ cartridge has 64 nozzles. On the color and photo BJ cartridge, the first 16 nozzles are for yellow, the next 8 nozzles are unused, the second set of 16 nozzles are for magenta, then a space of 8 nozzles, and the third set of 16 nozzles are for cyan.

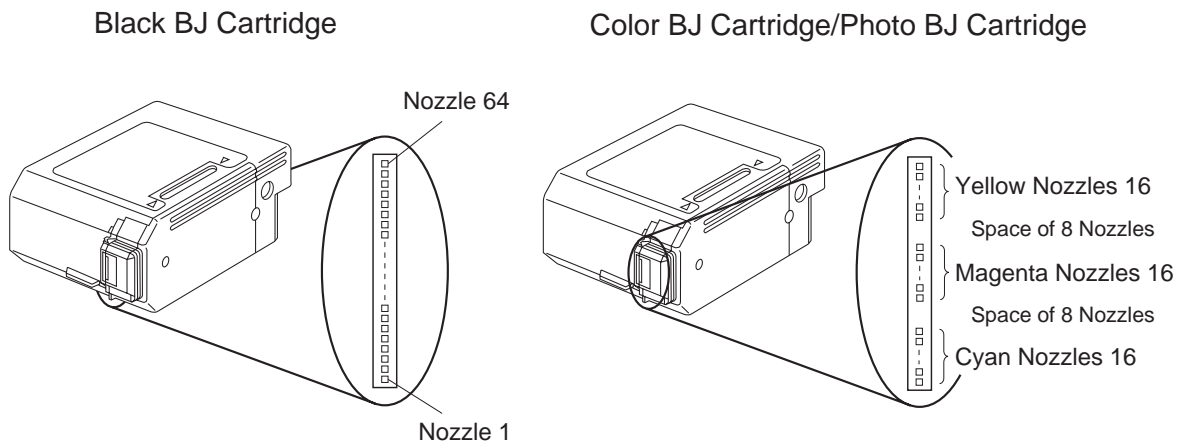

Figure 4-10 Nozzle Arrangement

3) Signal connection point (contact pad)

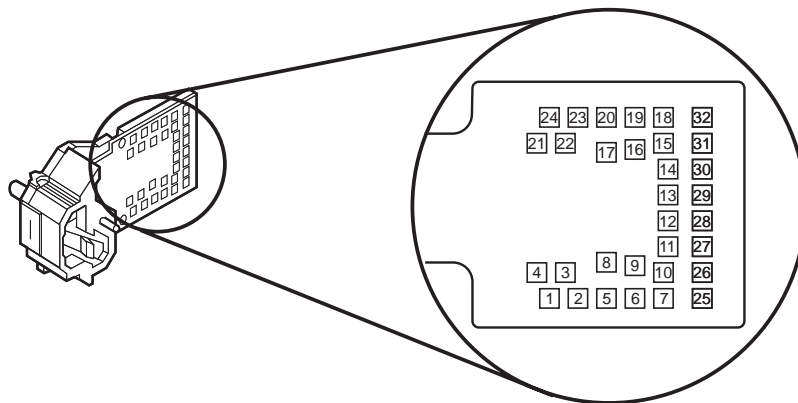

Figure 4-11 Contact Pad

4) Circuit diagram

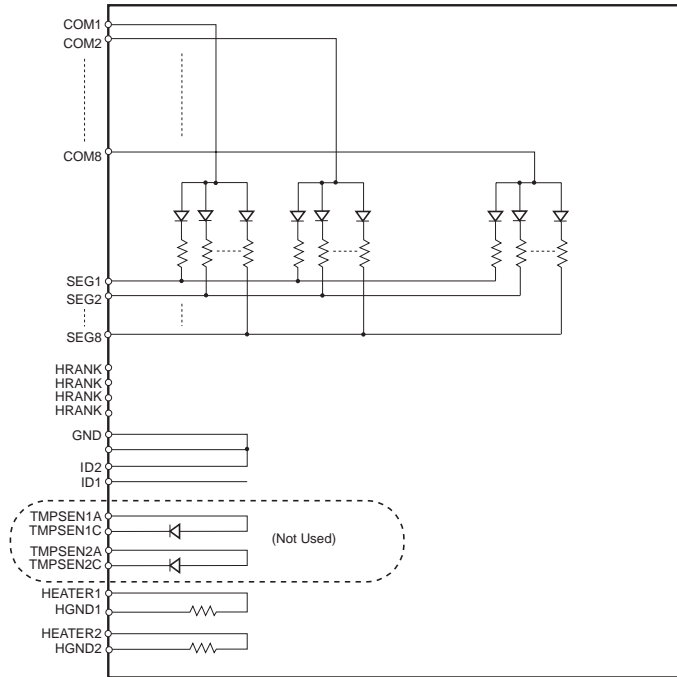

Figure 4-12 Bubble Jet Head Driver Block Diagram (Black BJ Cartridge)

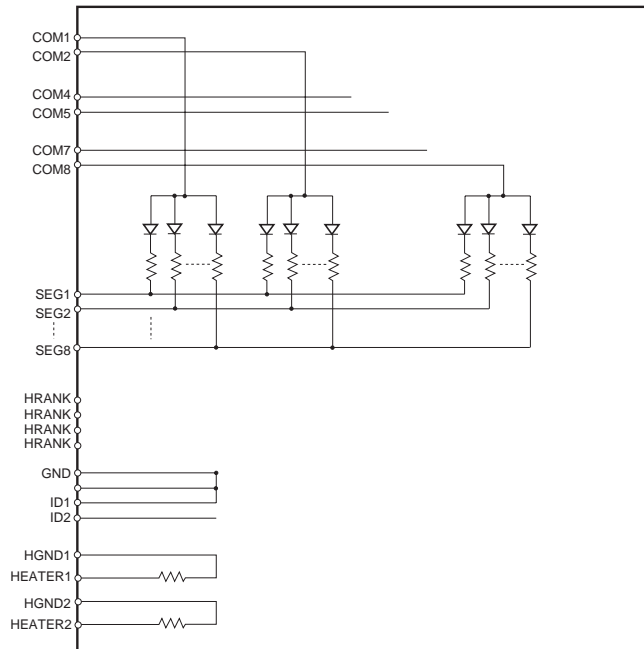

Figure 4-13 Bubble Jet Head Driver Block Diagram (Color BJ Cartridge)

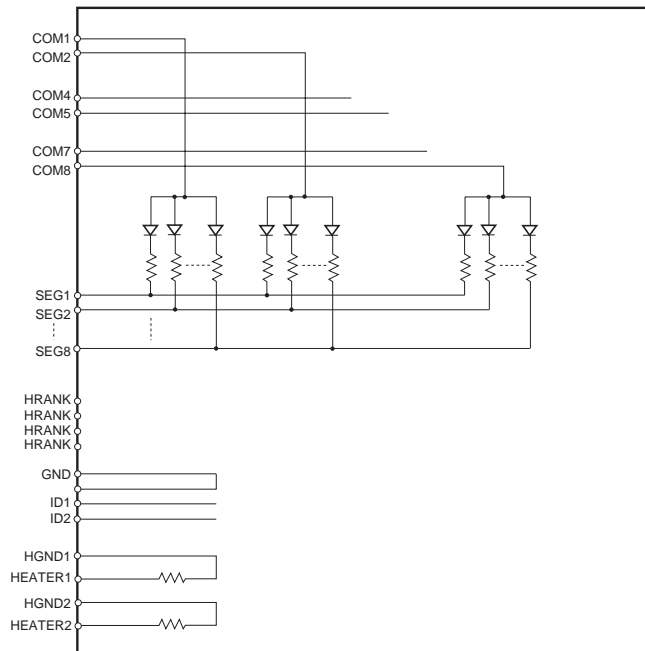

Figure 4-14 Bubble Jet Head Driver Block Diagram (Photo BJ Cartridge)

5) Head rank ID

One of four head rank IDs is selected to correct production variations in the bubble jet head units. The head rank ID is displayed by a PCB pattern of contact points of the bubble jet head unit. (BJ Cartridge PIN No. 29, 30, 31, 32)

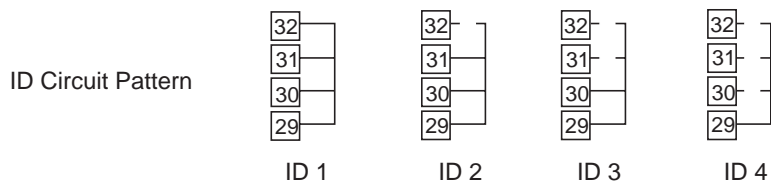
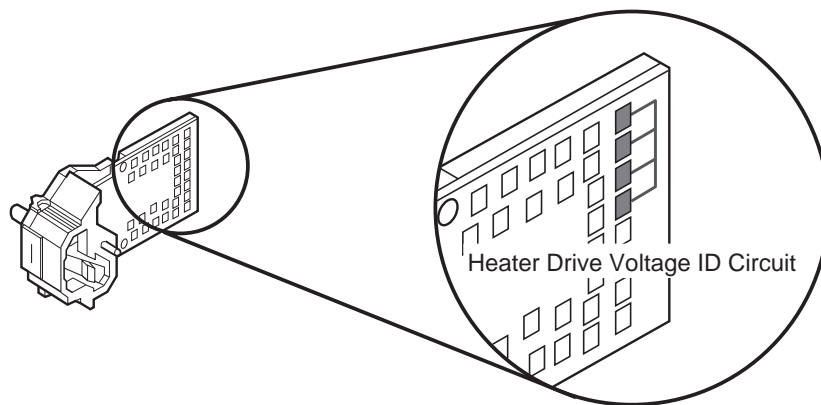

Figure 4-15 Head Rank ID

6) Temperature control

The optimum temperature of the BJ cartridge ink for high quality printing is about 23°C (73.4°F). The bubble jet head unit has warm-up heaters on the silicon plate. The black BJ cartridge, furthermore, has temperature sensors, but they are not used.

The printer controls the temperature by varying the heat pulse width (pre/main pulse width) of the SEG signal and turning the warm-up heaters on and off. The ambient temperature is detected by the temperature sensor on the printer logic board, not by the temperature sensors on the silicon plate. If it is 16°C (61°F) or less, the bubble jet head unit nozzles are warmed by the warm-up heaters.

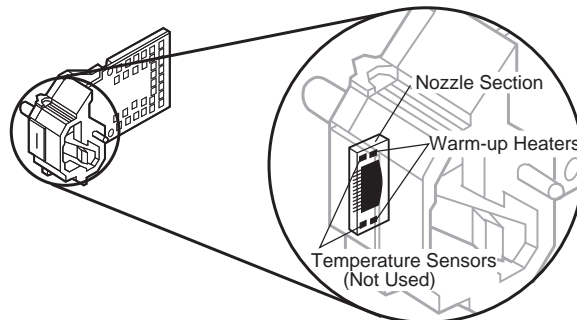

Figure 4-16 Head Temperature Controller

7) BJ cartridge detection feature

The presence or absence of the BJ cartridge is always monitored.

The contact between the terminal of the warm-up heater in the BJ cartridge and the carriage is checked.

8) BJ cartridge recognition feature

Whether the cartridge is a black, color, or photo BJ cartridge, it is determined by pins #11 and #15 on the J1 connector on the printer logic board.

Cartridge types can be distinguished with combinations of pins #11 and #15 as shown in the table below.

Pin No.	Signal name	Cartridge type		
		Black	Color	Photo
11	ID1	High	Low	High
15	ID2	Low	High	High

9) Print density control

This printer controls the quantity of ink ejected so it prints at constant density. It does this by predicting the change in the head temperature while printing and using the predicted temperature.

The quantity of ink ejected from the nozzles is controlled to obtain the optimum print density by controlling the heat pulse width (pre/main pulse width) every 50 ms based on the following information: the ambient temperature sensed by the temperature sensor on the logic board; the number of dots printed by the printer; the head temperature predicted from the switch-on time of the warm-up heater; and the head rank ID for correcting production variations of the bubble jet head unit (the heater drive voltage is fixed at 27.6 V DC).

3.3 Purge Unit

3.3.1 Purge unit functions

1) Capping function

The purge unit's cap is pressed against the face of the print head to prevent the ink from drying out or leaking.

If print data is not received for 60 seconds or more during a printing operation, the purge unit wipes the printing head face. If print data is still not received for another 60 seconds, the purge unit caps the printing head.

Other than during a printing operation, if print data is not received after a certain period of time (varies between 5 to 20 seconds), the purge unit caps the print head.

2) Cleaning function

The cleaning operation includes the wiping of paper and ink residue that has adhered to the printing head's face plate. It also sucks out ink from the printing head to replenish the inside of the nozzles with fresh ink.

The amount of ink consumed by the cleaning operation is as follows.

Black BJ Cartridge installed : 0.12 g

Color BJ Cartridge or Photo BJ Cartridge installed : 0.21 g

To maintain high printing quality, the purge unit cleans the printing head at the following times:

- After the AC power cord is connected.
- After the BJ cartridge is replaced.
- Before the printing operation is performed and it has been 72 hours since the last time the head was cleaned.
- When the printed dot count exceeds the set value.
- When the *RESUME* button is pressed down for 2 seconds or more.

3.3.2 Purge unit structure

1) Purge drive gear

The purge drive gear which is driven by the transmission gear activates the cam controlling the pumping operation. The transmission gear is rotated by the paper feed roller which is driven by the paper feed motor.

The cam's position is detected by the home position sensor via the sensor arm.

2) Wiper unit

When the carriage moves from left to right, the wiper retracts so that it does not touch the head. However, when the carriage moves from right to left, the wiper wipes off the ink from the BJ cartridge's face plate at the following times: when the printer is turned on, once every 60 seconds (or after a set dot count is reached) during printing, when the paper feed operation ends, when the pumping operation ends, and when the cap is opened or closed.

3) Cap unit

The cap unit has a rubber cap. When the carriage moves to the home position, the cap unit is pressed against the print head's face plate to cap it.

Also, since the cap is connected to a pump, the cap sucks ink out of the BJ cartridge during the pumping operation. The ink which has been sucked out is sent to the bottom cover unit's waste ink absorber.

4) Maintenance jet absorber

The maintenance jet absorber at the home position absorbs the ink ejected from the nozzles for a test to adjust the nozzles in the following cases: when the printer is turned on, during printing, when wiping occurs during printing, when paper feeding ends, when the pumping operation ends, and when the cap opens.

5) Slide lock pin

The slide lock pin moves the cap when the carriage moves from left to right and reaches the capping position. Capping is thereby executed and the slide arm is unlocked.

When the slide arm is unlocked, the feed roller's rotation is transmitted to the purge drive gear and sheet feeder.

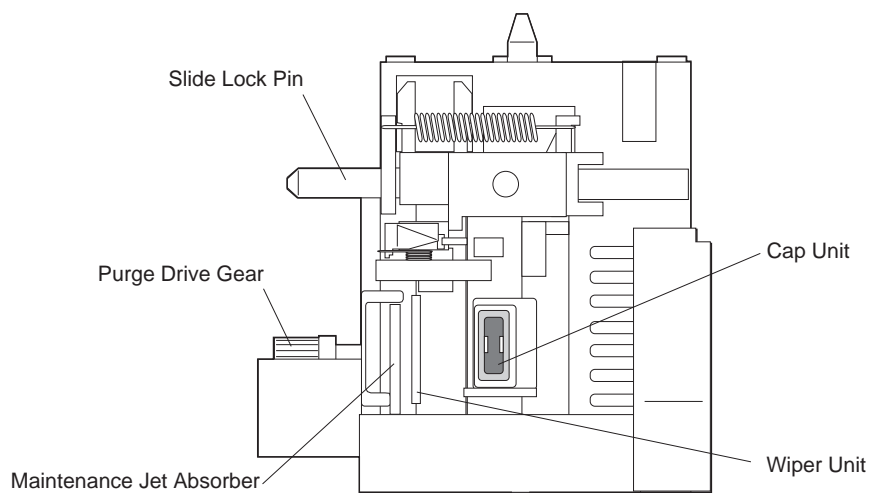

Figure 4-17 Purge Unit

3.4 Carriage

3.4.1 Carriage functions

1) Print head installation

The carriage holds the BJ cartridge mechanically with the carriage ribbon cable, and is connected to the circuit on the logic board.

2) Carriage driver

Driven by the carriage motor and carriage belt, the carriage moves across the paper horizontally.

3) Paper thickness adjustment

With the paper thickness lever at the top of the carriage, the gap between the paper and printing head can be adjusted.

4) Paper feed motor driver

When the carriage moves to the cleaning position at the right end, the slide arm is unlocked. The paper feed motor's drive power, normally used for paper feeding during printing, can be diverted to drive the purge unit and sheet feeder.

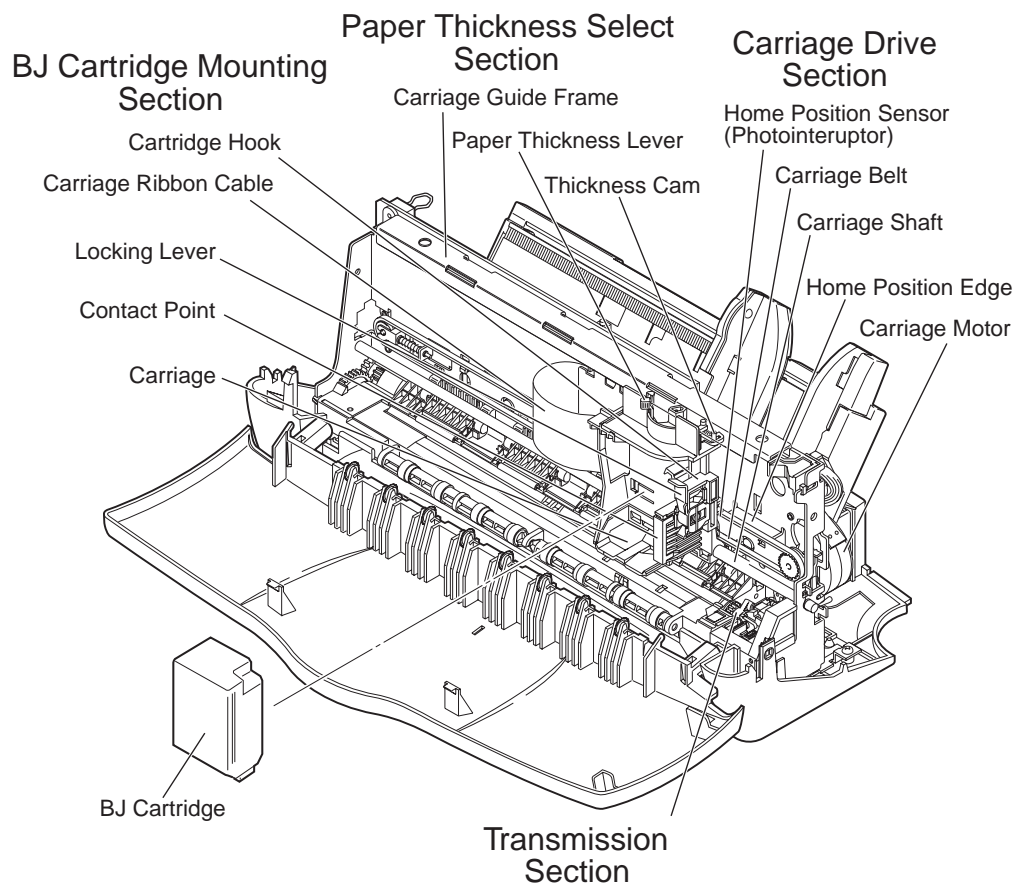

Figure 4-18 Carriage

3.4.2 Carriage structure

1) BJ cartridge mounting section

The cartridge holder moves with the locking lever which secures the BJ cartridge onto the carriage.

When a BJ cartridge is secured onto the carriage, the ribbon cable's signal contacts are pressed against the bubble jet head's signal contacts, enabling signals to be transmitted from the logic board.

2) Carriage driver

The stepping-type carriage motor drives the carriage horizontally across the paper by the carriage belt. After the photo interrupter type home position sensor behind the carriage detects the home position edge as the initial position, the carriage is controlled by the stepping pulse sent to the carriage motor.

The carriage motor is driven by a one to two-phase exciter at a fixed current.

Also, if a vertically-oriented line, etc., is printed from both carriage directions, it will appear to be crooked or misaligned due to mechanical reasons. However, if the vertically-oriented line is disjointed or not continuous, any misalignment will not be that noticeable and printing is executed from both carriage directions. The slightly-off timing of the detected home position edge is automatically corrected with the software.

3) Paper thickness setting

When envelopes or thick paper are fed for printing, they will rub against the head face causing possible damage and paper contamination. This can be prevented by using the proper paper thickness setting.

The gap between the head and paper must be set to the optimum setting (one of two settings) to match the thickness of paper being fed. This gap is adjusted by changing the angle of the carriage guide frame and the carriage attachment angle. The gap between the platen and head thereby changes.

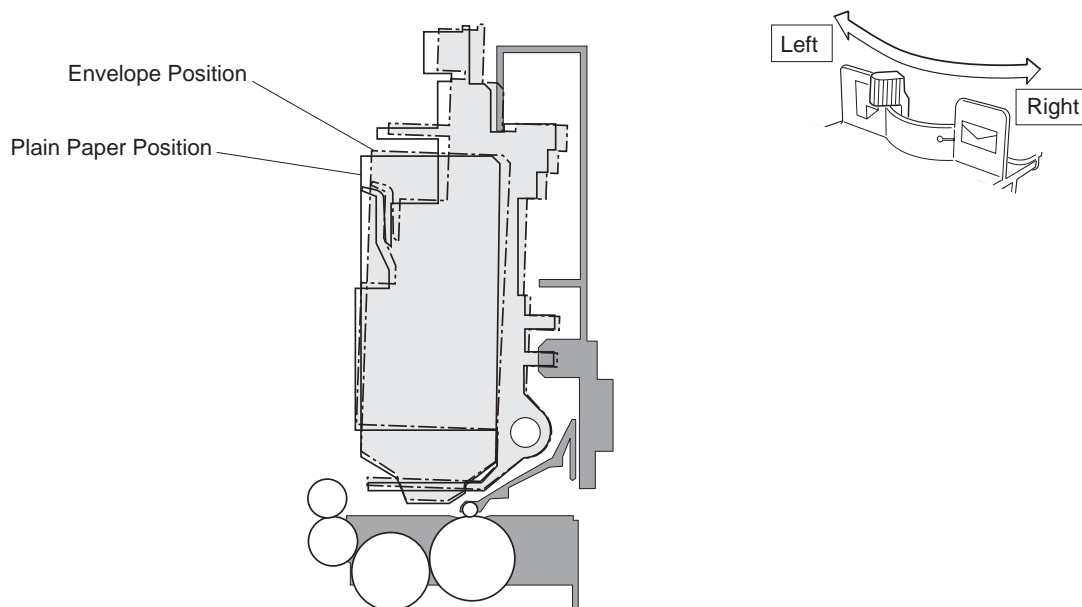

Figure 4-19 Paper Thickness Adjustment

4) Switching the paper feed motor drive transmission

The paper feed motor drives either the paper feed, purge unit, or cut sheet feeder according to the position of the carriage. When the carriage is not at the right end, the slide arm is locked by the purge unit's slide lock pin. In this condition, the paper feed is driven by the feed roller. When the carriage is at the capping position, the slide arm is unlocked and the paper feed motor drives the purge unit and sheet feeder.

When the slide arm is unlocked and the feed roller rotates in the feeding direction, the slide arm rotates until it reaches the cut sheet feeder gear to drive the gear.

When the slide arm is unlocked and the feed roller is rotated in the opposite direction of the feeding direction, the slide arm rotates until it reaches the purge drive gear to drive the gear.

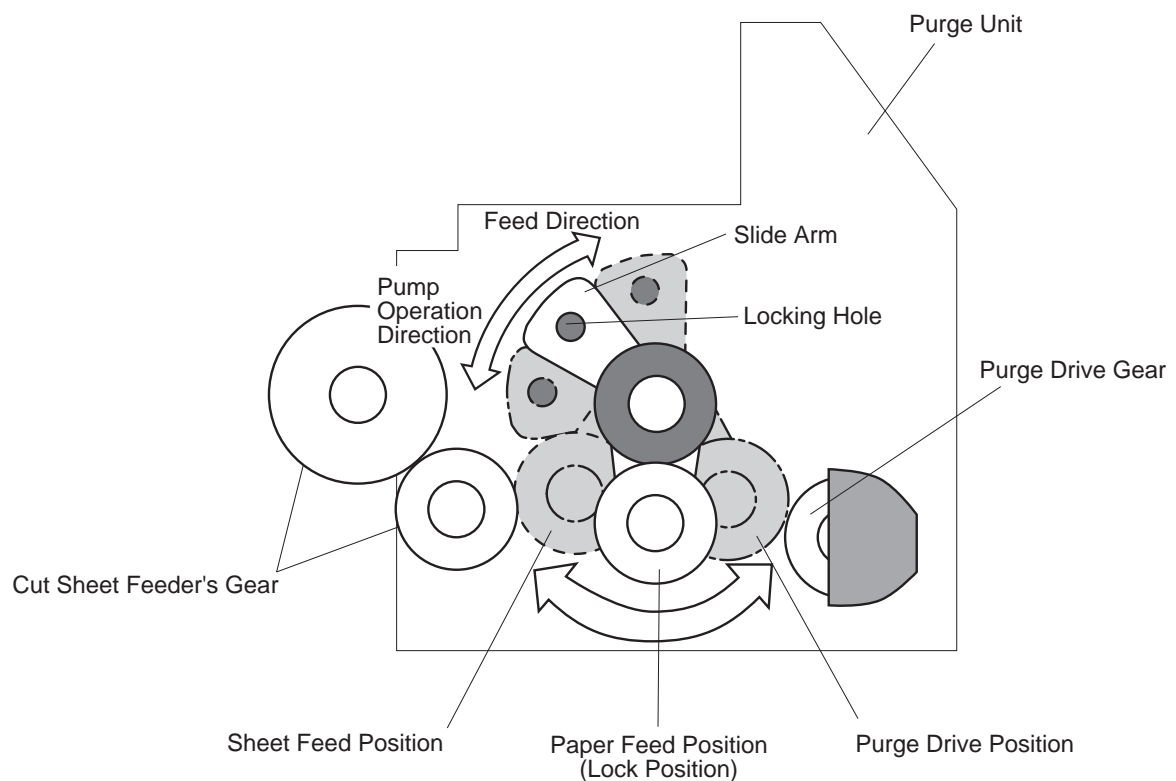

Figure 4-20 Paper Feed Motor Drive Transmission

3.5 Paper Feed

3.5.1 Outline of the paper feed

1) Paper feed mechanism

The paper feed mechanism supplies paper from the built-in cut-sheet feeder. The built-in cut sheet feeder is driven by the paper feed motor. Paper stacked in the sheet feeder is picked up and fed automatically. Even thick paper like envelopes can be fed automatically without selecting the paper type mechanically with the paper selection lever.

When the paper is sensed by the paper end sensor, it is fed automatically by the paper feed roller until it reaches the starting position for printing on the platen.

During printing, the paper is fed by the rotation of the paper feed roller.

The paper, after printing, is delivered by the eject roller.

2) Paper feed operation

It is not possible to perform paper feed operations with the printer, however, paper ejection can be performed with the *RESUME* button.

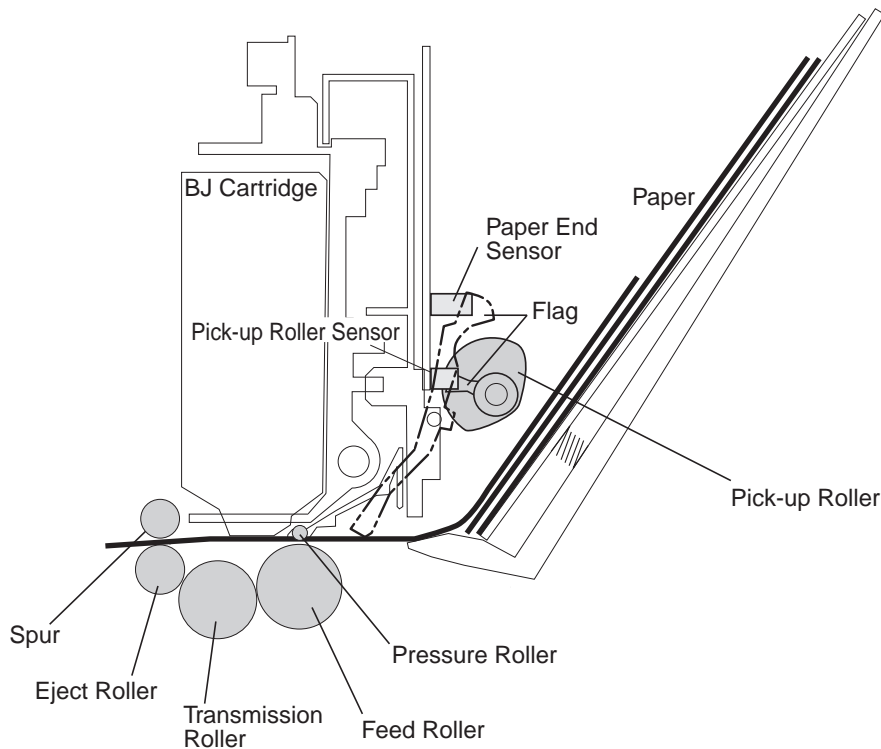

Figure 4-21 Paper Feed Mechanism

3.5.2 Structure of the sheet feeder

This printer has no paper selection lever on the cut sheet feeder.

If the paper meets specifications, it can be fed without selecting the paper type. The paper is loaded in the cut sheet feeder such that a corner of it is caught by the paper separator. When printing starts, the pick-up roller starts to rotate through the drive of the paper feed motor. Plain paper is fed with its corner held by the paper separator, and then pushed into the paper feed section. When printing on thick paper like envelopes, as the paper is stiffer than the return force of the paper separator's spring, the paper separator is pressed down to feed the paper.

The initial position of the pick-up roller is detected when the flag is sensed by the pick-up roller sensor on the logic board.

When paper is sensed by the paper end sensor for over a second, it is fed automatically until it reaches the starting position for printing.

When the paper pick-up operation is executed, if no paper is sensed, it is executed again. If the paper is still not sensed, it is assessed as a paper feed error.

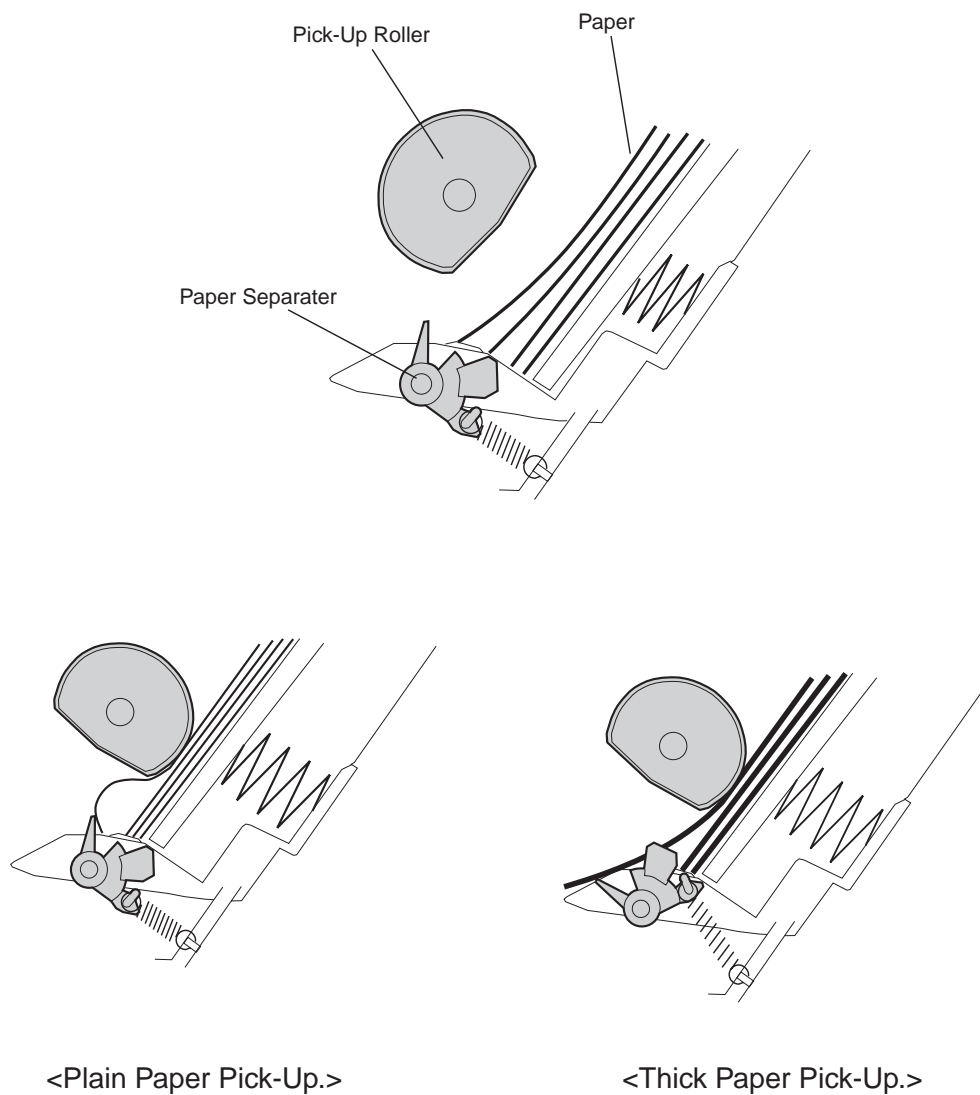

Figure 4-22 Paper Separator

4. PRINTER ELECTRICAL SYSTEM

4.1 Overview

The electrical system functions are handled by the logic section or power supply. The logic section converts the data from the interface into print signals or printer operation signals and drives the BJ cartridge and motors while monitoring the status of the sensors.

The power supply unit consists of a built in AC adapter which provides DC output to the logic board, motors, and head etc. When DC input power from the AC adapter is being supplied, all of the hardware components are active.

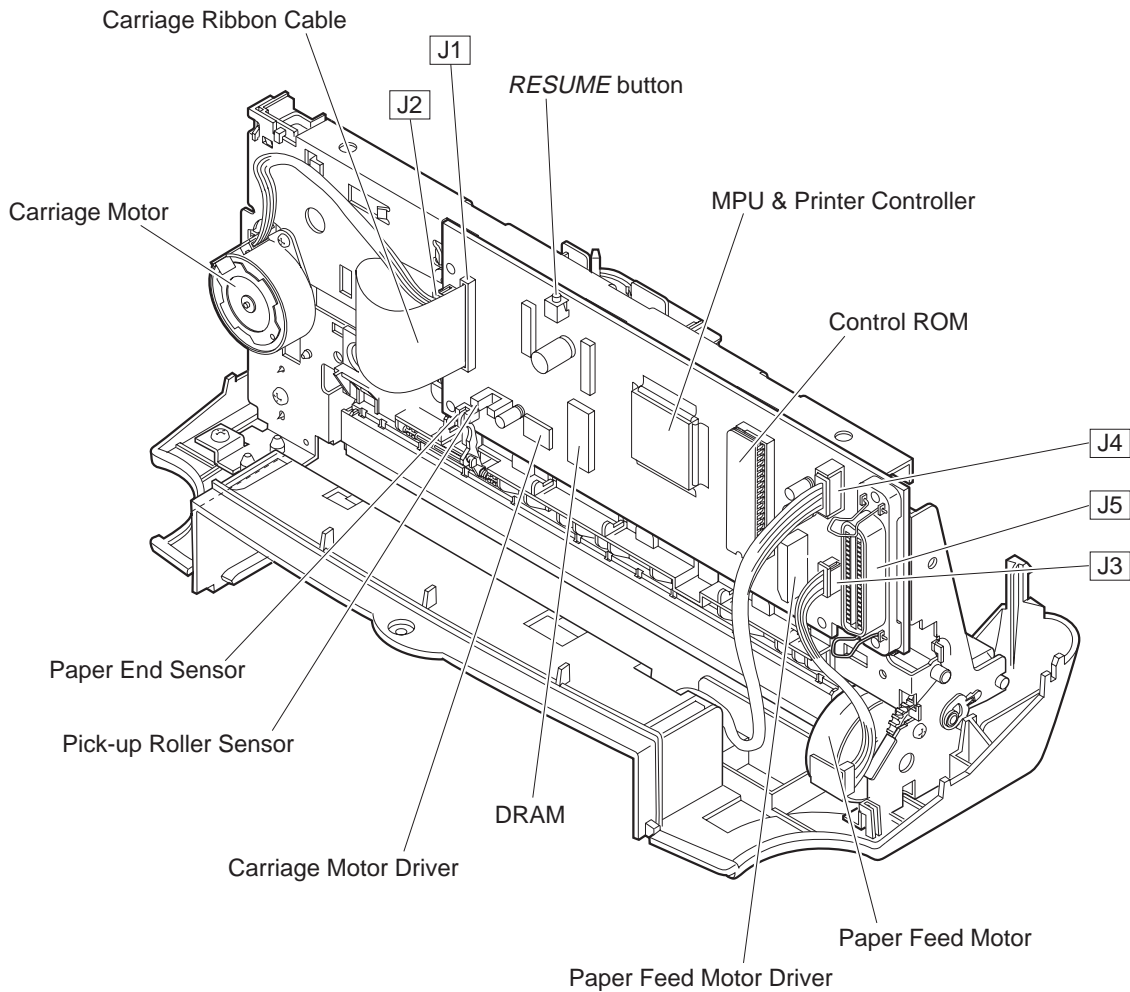

Figure 4-23 Printer Electrical System

4.2 Logic Section

4.2.1 Logic section block diagram

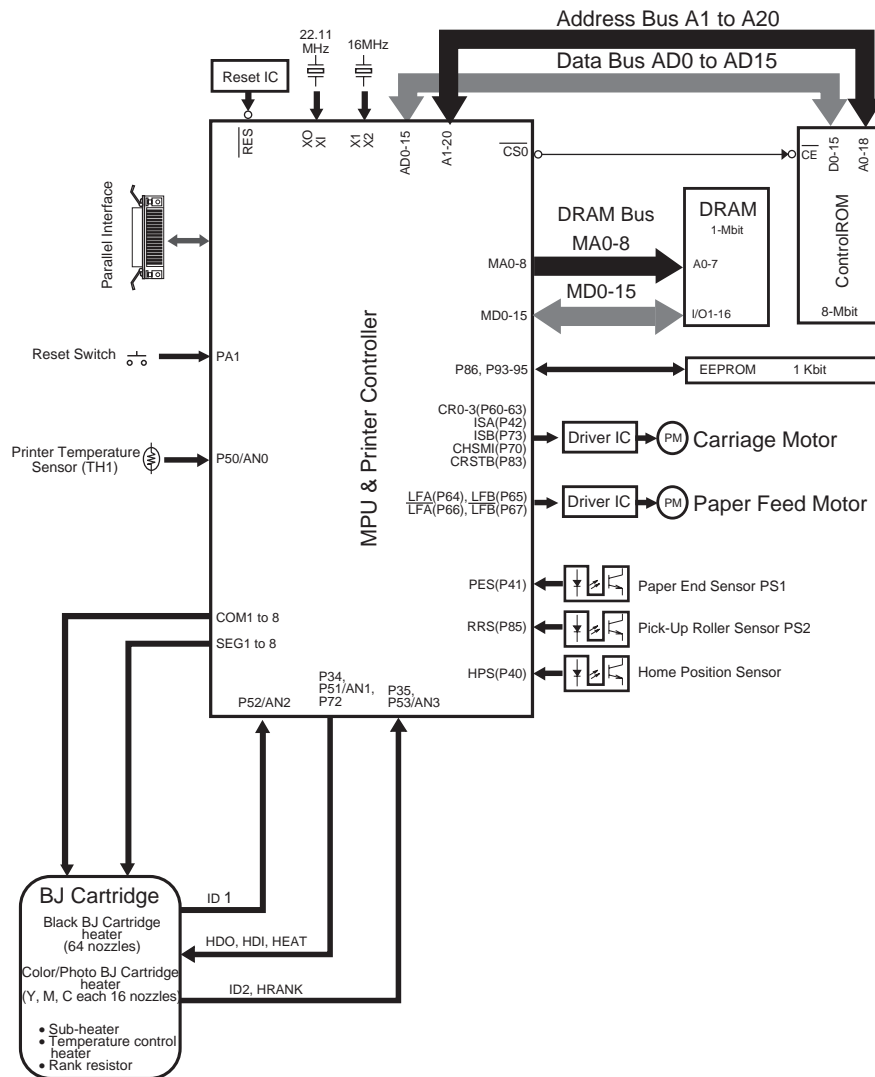

Figure 4-24 Logic Board Block Diagram

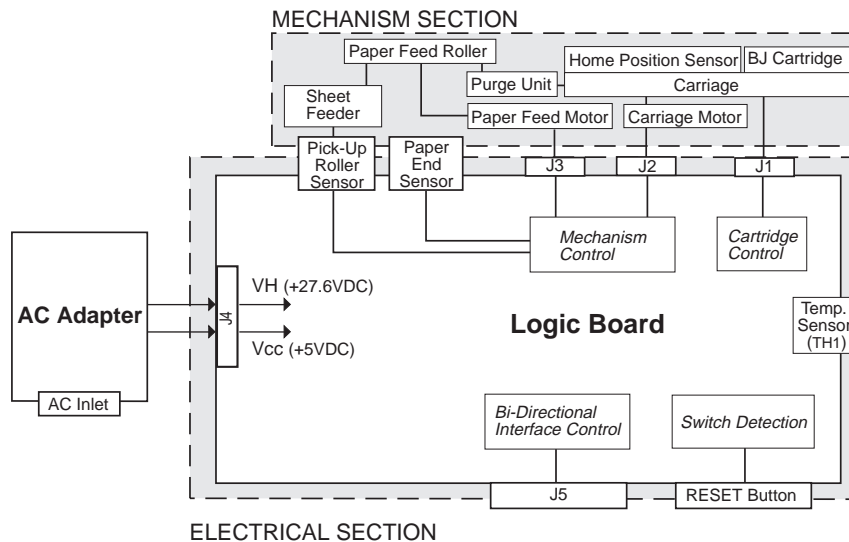

Figure 4-25 Printer Block Diagram

4.2.2 Logic section components

1) MPU & Printer controller (IC1)

The MPU & Printer controller contains a 16-bit CPU, 1K-bit RAM, 20-bit address bus port, 16-bit data bus port, stepping motor controller, A-D converter, interface controller, DRAM controller, buffer controller, print head controller, I/O port, and other components.

MPU & Printer controller is synchronized with 16 MHz and 22.11 MHz external clock input.

Built-in CPU

The 16-bit CPU generates the 8 MHz clock from the 16 MHz external clock input and is synchronized with the clock.

Address bus

The 20-bit address bus port is connected to an 8 M-bit control ROM and printer controller.

Data bus

Like the address bus, the 16-bit data bus port is connected to the 8 M-bit control ROM.

Stepping motor controller

The stepping motor controller outputs the carriage motor's single- and two-phase exciter drive signal and paper feed motor's two-phase exciter drive signal.

The stepping motor controller switches the carriage motor with the 5-step peak current value for optimum driving. The stepping motor controller outputs the switching control signal to the carriage motor driver.

A-D converter

The A-D converter digitally converts the following external analog signals received/sent through the I/O port to enable them to be detected by the MPU & printer controller:

AN0: The printer's internal temperature is detected by the thermistor on the logic board.

AN1: It detects whether the BJ cartridge is installed in the printer, or not.

AN2: It monitors the VH voltage which drives the head of the cartridge.

AN3: The head rank is detected by the rank resistor in the BJ cartridge.

Interface controller

The interface controller receives from the computer, 8-bit parallel data which is synchronized with the data strobe pulse (STROBE) through the BUSY/ACKNLG handshake. It also controls other interface signals.

DRAM controller

The DRAM controller controls the 1 M bit DRAM's 8-bit addressbus and 16-bit data bus and also executes read/write control, RAS/CAS control, and refresh control.

Buffer controller

The buffer controller automatically reads the print buffer, and clears the data after it is read.

Print head controller

The print head controller counts the number of dots of the bit map print data read from the DRAM print buffer to control the heat pulse width (pre/main pulse width), converts it to the COM and SEG signals for 8 x 8 matrix printing control, and controls heating of the heater plate of the bubble jet nozzles of the BJ cartridge.

I/O port

Signals for the setting statuses determined by the *RESUME* button, head ID, paper end sensor, home position sensor, pick-up roller sensor, head rank resistor, thermistor, and head-driving voltage (VH) monitor are input through the input ports. Signals for operations such as BJ cartridge detection and head-driving voltage control are output from the output ports.

2) Control ROM (IC3)

The 8 M-bit control ROM contains the program for printer control.

3) DRAM (IC4)

Controlled by the printer controller, the 1 M-bit DRAM is used as print buffer and working area.

4) Reset IC (IC7)

This IC detects the power voltage when power on or instantaneous power failure occur and resets the MPU & Printer controller.

5) EEPROM (IC8)

Controlled by the printer controller, the 1 K-bit EEPROM (Electrically Erasable and Programmable ROM) stores various function settings, the total count of printed sheets, and the total waste ink amount.

6) Paper feed motor driver IC (IC6)

Controlled by the MPU & Printer controller, the paper feed motor driver drives the paper feed motor (controlled by the two-phase exciter) with a constant-voltage unipolar drive. The driver IC has four same circuits.

7) Carriage motor driver IC (IC12)

Controlled by the MPU & Printer controller, the carriage motor driver drives the carriage motor (controlled by the one to two-phase exciter) with a fixed current bipolar drive. In accordance with the switching signal from the MPU & Printer controller, the peak current value is set to five steps and driven. The driver IC has two same circuits.

5. SENSOR FUNCTIONS

The printer has a pick-up roller sensor, paper end sensor, home position sensor (purge sensor), printer temperature sensor, and head temperature sensor.

Also, the EEPROM counts and records the waste ink absorption amount. When the waste ink absorber becomes full, the waste ink absorption amount indicates an error.

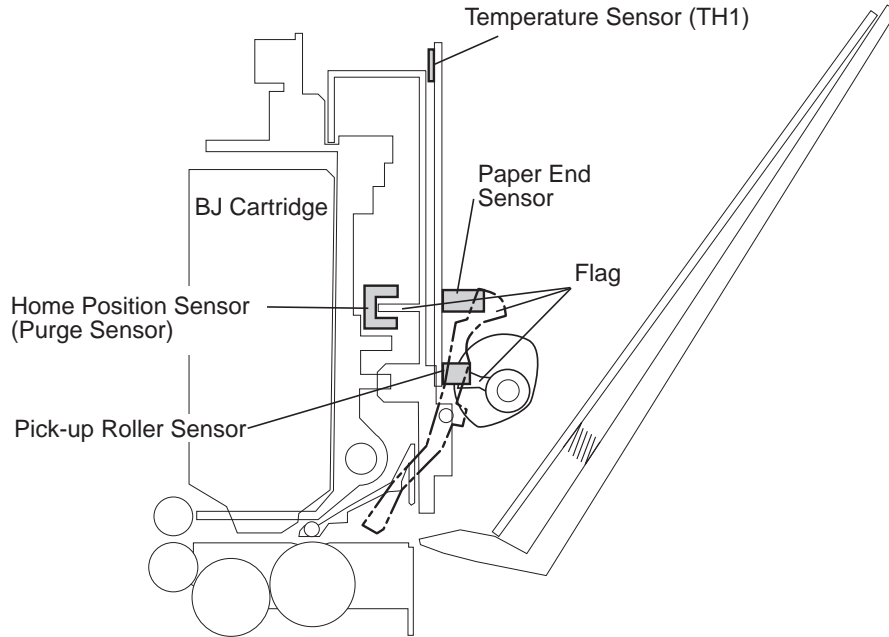

Figure 4-26 Sensors

5.1 Pick-up Roller Sensor

The photo interrupter-type pick-up roller sensor detects the initial position of the sheet feeder's pick-up roller. When the initial position is detected, the flag interrupts the sensor.

5.2 Paper End Sensor

The photo interrupter-type paper end sensor detects with the paper sensor arm's flag when a sheet of paper passes through the paper feeding mechanism. When the flag interrupts the sensor, the sensor does not detect the paper. When the flag does not interrupt the sensor, the sensor detects the paper.

5.3 Home Position Sensor (Purge Sensor)

The photo interrupter-type home position sensor senses the home position edge and detects the carriage position. After the edge is detected, the carriage moves to the right. At the home position, the maintenance jet is executed.

Also, at the capping position, the on/off of the home position sensor (purge sensor) flag during the recovery operation is detected.

5.4 Temperature Sensor

The temperature sensor is a thermistor which detects the printer's internal temperature. The thermistor's resistance changes along with any temperature changes. The change in the resistance is detected as a change in the voltage by the MPU & Printer controller. The analog value input to the MPU & Printer controller is converted into a digital value by the internal A-D converter. The temperature is thereby detected. After the printer temperature is detected, the head-driving and head temperature adjustment signal are controlled accordingly.

5.5 Waste Ink Amount Detection

Waste ink is discharged for head maintenance and absorbed by the waste ink absorber. If the amount of waste ink discharged exceeds the absorption capacity of the waste ink absorber, ink might leak from the printer.

To prevent ink from leaking, the waste ink absorber capacity is estimated and detected when full.

The waste ink is discharged during maintenance jet and recovery. The amount of waste ink discharged is estimated by counting the number of maintenance jet and recovery. Then the waste ink amount with evaporated ink is calculated. When the calculated waste ink amount exceeds the capacity of the waste ink absorber, a waste ink-full error occurs.

TABLE 4-2 LIST OF SENSOR FUNCTIONS

Sensor Function	Description	Status
Paper detection	Detected by the paper sensor	Provided
Home position detection	Detected by the home position sensor	Provided
BJ cartridge detection	Detected by the HEATER signal of BJ cartridge	Provided
BJ cartridge identification	Identified by combination of the ID1 and ID2 signals (pins #11 and #15 of connector J1 on the control board).*	Provided
Waste ink amount detection	Calculated with the maintenance jet dot count	Provided
Paper width detection		Not provided
Ink detection		Not provided

*: Cartridge types can be distinguished with combinations of the ID1 and ID2 signals as shown in the table below.

Pin No.	Signal name	Cartridge type		
		Black	Color	Photo
11	ID1	High	Low	High
15	ID2	Low	High	High

This page intentionally left blank



Part 5

MAINTENANCE

Page	
5 - 1	1. MAINTENANCE & SERVICING TOOLS
5 - 1	1.1 Maintenance
5 - 1	1.2 Servicing Tools
5 - 2	2. GREASE APPLICATION
5 - 3	3. DISASSEMBLY AND REASSEMBLY
5 - 3	3.1 Disassembly and Reassembly
5 - 3	3.2 Disassembly and Reassembly Cautions
5 - 4	3.3 Logic Board and Bottom Cover Replacement Cautions
5 - 5	4. TROUBLESHOOTING
5 - 5	4.1 Troubleshooting
5 - 7	4.2 Error Condition Diagnosis
5 -21	5. LOCATION & SIGNAL ASSIGNMENT
5 -21	5.1 Logic Board
5 -23	5.2 Carriage Ribbon Cable
5 -24	5.3 BJ Cartridges
5 -25	6. CIRCUIT DIAGRAMS
5 -25	6.1 Parts Layout
5 -27	6.2 Circuit Diagram

1. MAINTENANCE & SERVICING TOOLS

1.1 Maintenance

1.1.1 Parts for Regular Replacement

Level	Part
User	None
Service personnel	None

1.1.2 Consumables

Level	Consumable
User	Black BJ cartridge Color BJ cartridge Photo BJ cartridge
Service personnel	None

1.1.3 Periodic Maintenance

Level	Periodic Maintenance
User	None
Service personnel	None

1.2 Servicing Tools

Ordinary Tool	Use
Phillips screwdriver	For removing screws
Blade screwdriver	For removing plastic parts
Tweezers	For installing and removing coil springs
Multi-meter	For troubleshooting

Special Tool (Parts Number)	Use
Grease MOLYKOTE PG-641 (CK-0562-000)	Apply to the specified place as shown in Figure 5-1

2. GREASE APPLICATION

Use the special tool to apply grease at the points and amounts shown below.

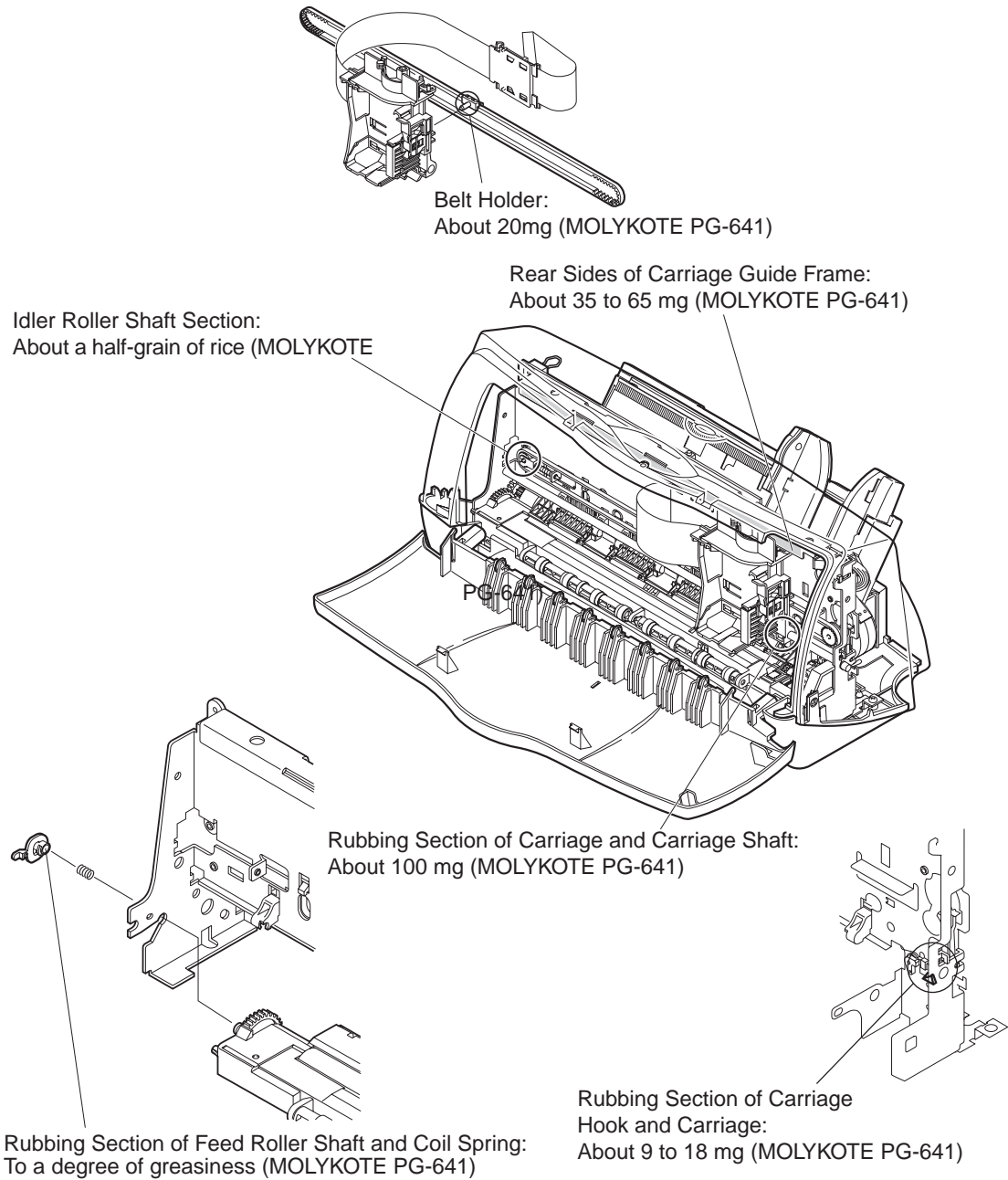

Figure 5-1 Grease Application Points

3. DISASSEMBLY AND REASSEMBLY

3.1 Disassembly and Reassembly

When disassembling or reassembling the printer, refer to the parts catalog. In the parts catalog, figure numbers are in the order of disassembly. Close-up diagrams are also provided for additional detail.

3.2 Disassembly and Reassembly Cautions

When disassembling or reassembling the printer, note the following precautions. These cautions are also provided in the parts catalog.

3.3 Logic Board and Bottom Cover Replacement Cautions

3.3.1 Logic board replacement cautions

The various settings, waste ink amount, and other data stored in the logic board's EEPROM cannot be rewritten into the new EEPROM after the logic board is replaced. The data in the new logic board's EEPROM is not set. After the logic board/EEPROM is replaced, reset the EEPROM as described in "Part 3: 2.4 EEPROM Reset" (page 3-13). When replacing the logic board, visually check the amount of waste ink in the waste ink absorber. Replace the bottom cover if necessary. Depending on the amount of waste ink already absorbed, ink may leak even before a waste ink-full error warning appears.

However, it is not necessary to replace it if the printer has been used for less than 2 weeks and less than 50 pages have been printed out.

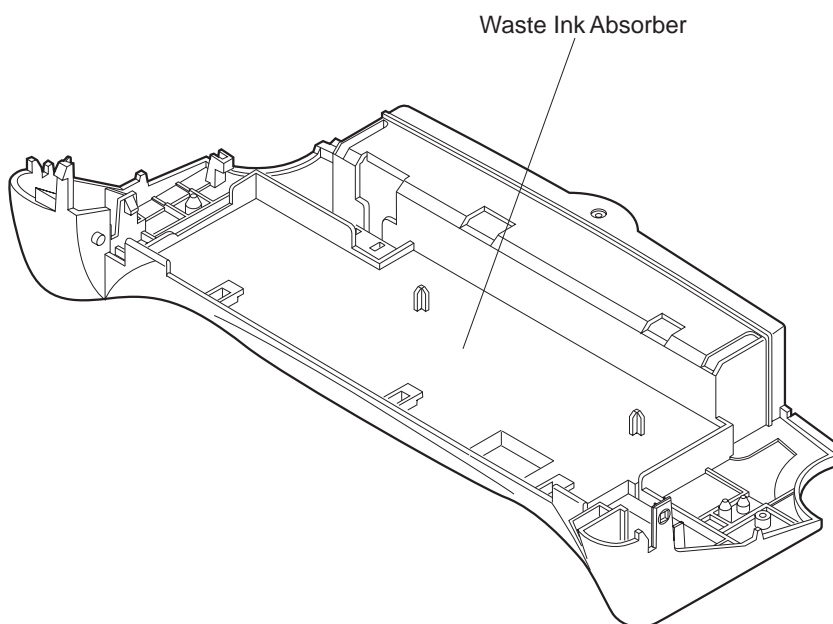

Figure 5-2 Bottom Cover

3.3.2 Cautions after replacing the bottom cover

After a waste ink-full error occurs and the bottom cover are replaced, reset the EEPROM.



When a waste ink-full error occurs, it can be assumed that the printer has printed more sheets than its service life called for. However, this depends on how many times the cartridge has been replaced and the usage conditions. When a color BJ cartridge is used, more ink is consumed due to head maintenance as compared to a black BJ cartridge. Therefore, the waste ink amount will also be more.

4. TROUBLESHOOTING

4.1 Troubleshooting

4.1.1 Overview

This chapter consists of the following two sections on subsequent pages: “Error condition diagnosis” for diagnosing the problem when the cause is unknown and “Symptoms” for resolving problems whose cause is known.

If the cause of the problem is unknown, diagnose the problem. And if the cause is known, follow the countermeasures to resolve the problem.

4.1.2 Troubleshooting cautions

1. Before troubleshooting, make sure the connectors and ribbon cable are properly connected. If the problem occurs at random, be sure to check the connections.
2. When servicing the printer with its outer casing removed and the AC adapter connected, beware of electrical shocks and PCB short circuiting.
3. Troubleshooting is described in flowchart form.

The following symbols are used in the flowcharts.

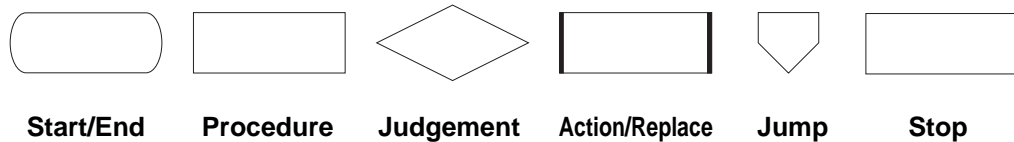

4. If there is a problem with the printing quality or paper feeding, first check that the printer's installation location and paper meet the required specifications. Also check that the paper select lever and the paper thickness lever are set correctly and that the paper is loaded properly.
5. After replacing parts or repairing the printer, be sure to make a test print to confirm that the problem has been fixed.
If the problem still persists, troubleshoot again while skipping the steps already executed.

Example

Countermeasure: After replacing the BJ cartridge, execute a test printout to check whether the problem has been fixed.

If the problem persists, execute the next countermeasure step 2 which calls for the replacement of the logic board.

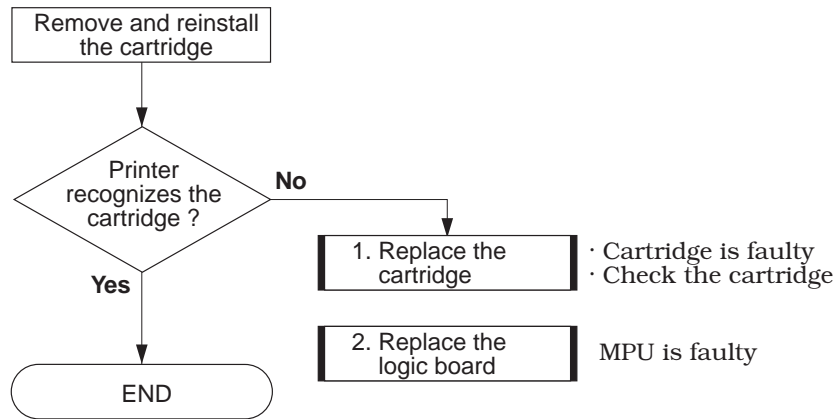

6. After completing the troubleshooting, be sure to reconnect connectors and tighten any loosened screws.



When replacing the logic board, be sure to check the waste ink absorbers' ink amount on the rear of the printer base unit. If necessary, reset the EEPROM.

Refer to *Part 3, 2.4 EEPROM Reset (page 3-13)* and *Part 5, 3.3 Logic Board and Bottom Cover Replacement Cautions (page 5-4)*.

4.2 Error Condition Diagnosis

4.2.1 Initial self check

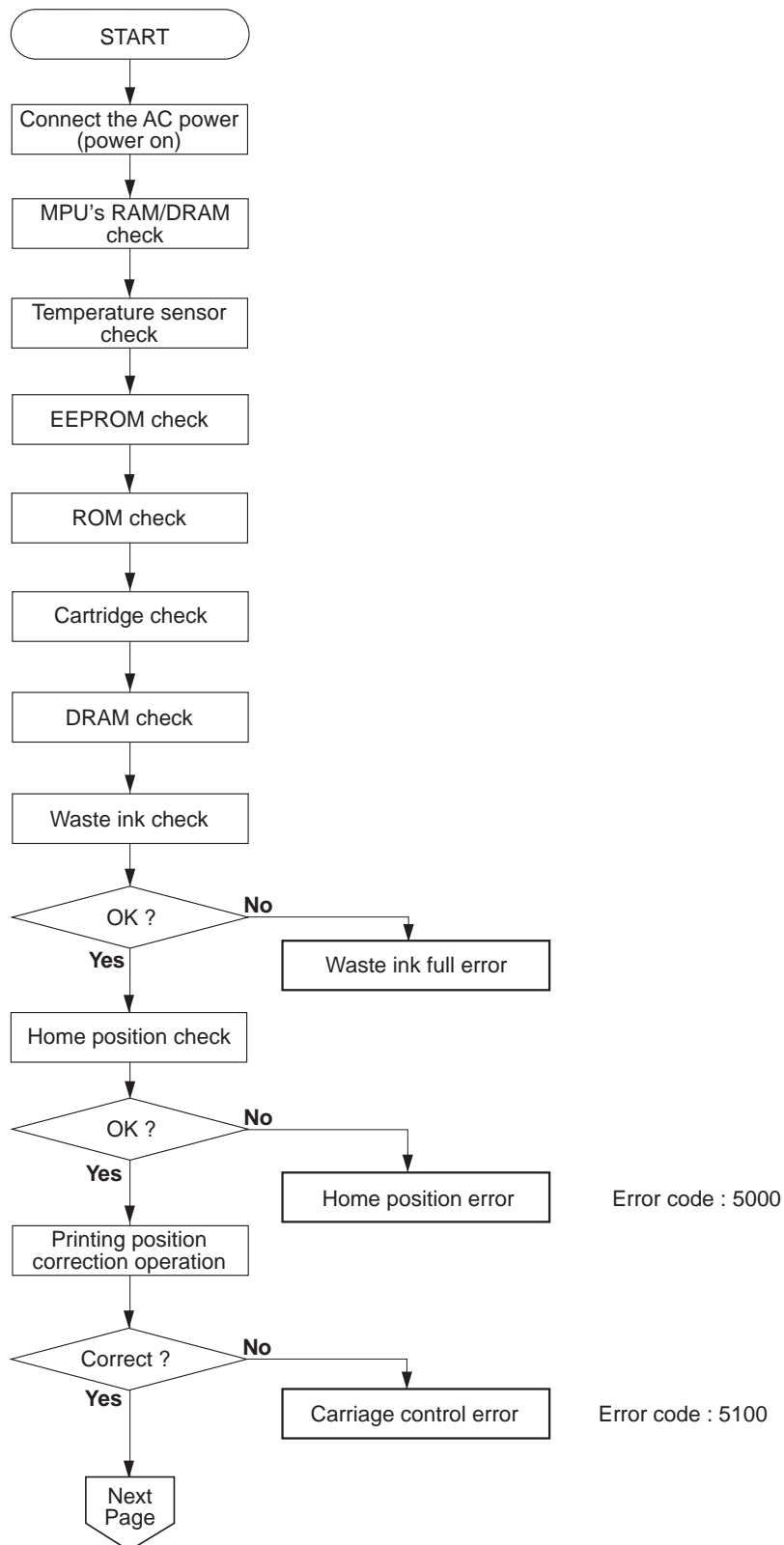

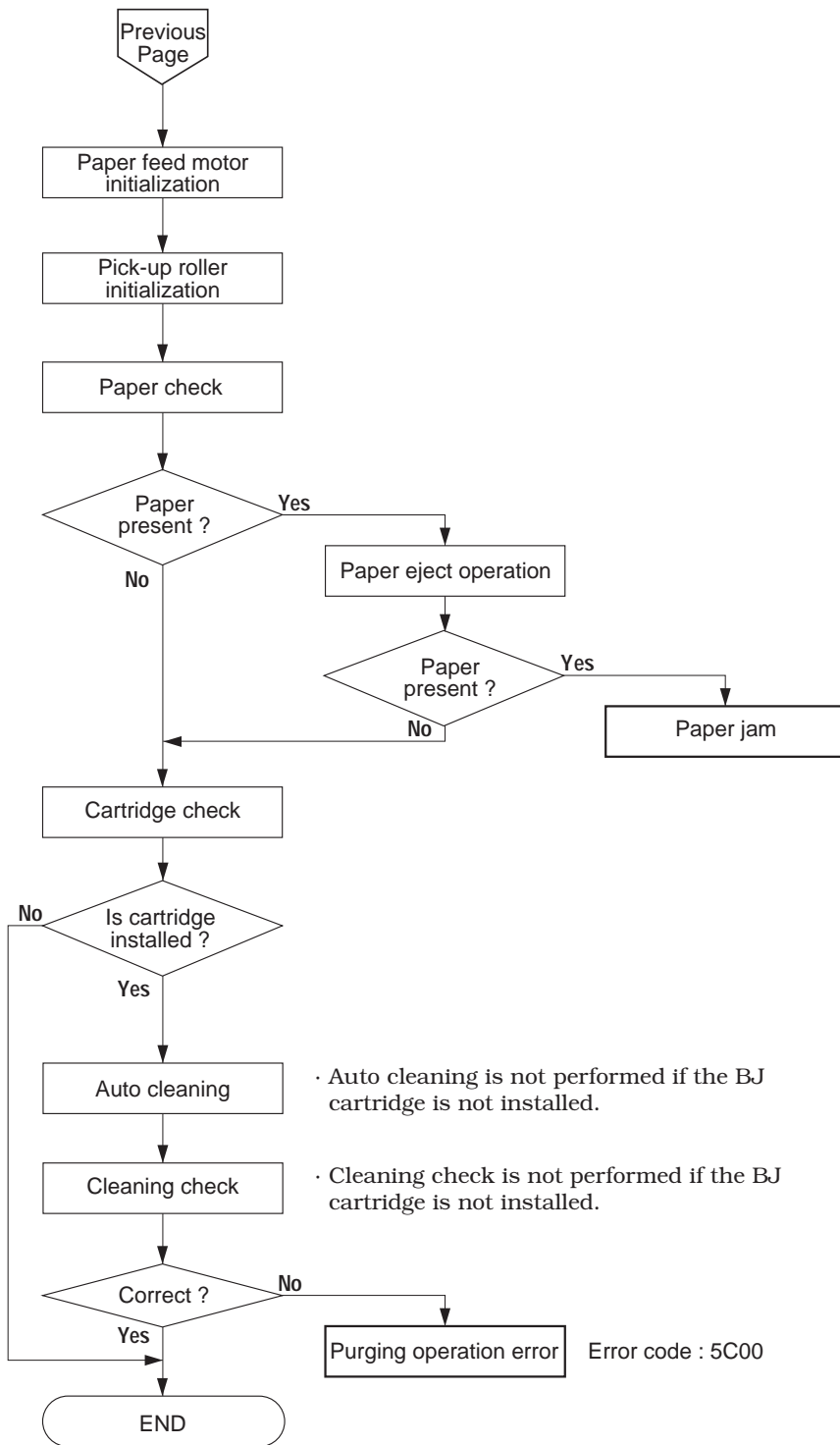

4.2.2 Error recovery

a) Error display

1.No Cartridge Error (Code : 5600)

<Cause> The cartridge is not installed correctly.

<Suspected Parts> Cartridge, logic board, carriage connector

<Measure>

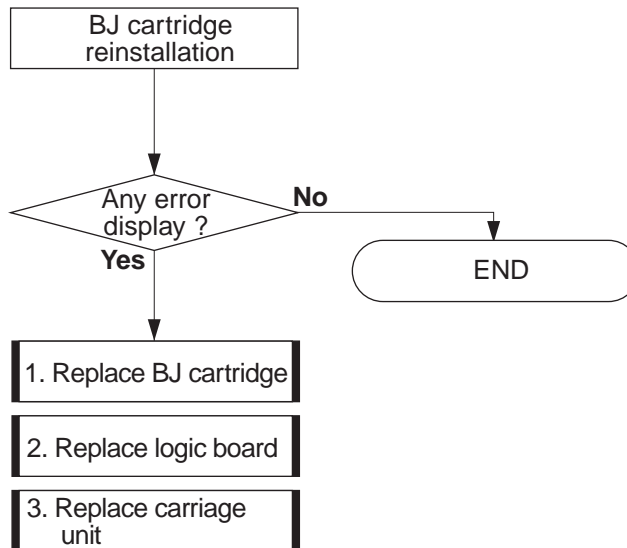

2.Home Position Error (Code : 5000)

<Cause> The home position cannot be detected.

<Suspected Parts> Home position sensor, carriage motor, logic board, carriage ribbon cable

<Measure>

Visual check of carriage drive mechanism

- Check for any paper jams, carriage belt wear/deterioration/dislocation, deformation of the carriage or carriage guide, scratching or bending in the carriage shaft, etc.
- Move the carriage by hand and check that it moves smoothly and there is no abnormal noise.

Correct ?

No

Repair/replace faulty parts

Yes

Carriage motor operation check

- Turns on during initialization ?
- Out of sync ?

Correct ?

No

Carriage motor check

Yes

Measuring points		Normal reading
J2	1-2	Approx. 11 Ω
Pin No.	3-4	

Correct ?

No

Replace carriage motor

Yes

Replace logic board and check waste ink absorbers

Home position sensor check

Measuring points **Sensor** **Normal reading**

J1	Open	Low level
Pin No. 29	Closed	High level

While the power is on, open the front cover and remove the BJ cartridge. Move the carriage's home position sensor by hand and check.

Correct ?

No

Replace carriage unit

- Home position sensor is faulty
- Ribbon cable is loose

Yes

Replace logic board

- MPU & Printer controller is faulty.

3. Paper Feed Error/Paper Jam

- <Cause>**
- The paper feed operation is executed but the paper is not fed.
 - The paper eject operation is executed but the paper is not ejected.

<Suspected Parts> Paper feed mechanism, pick-up roller sensor, paper end sensor, logic board

<Measure>

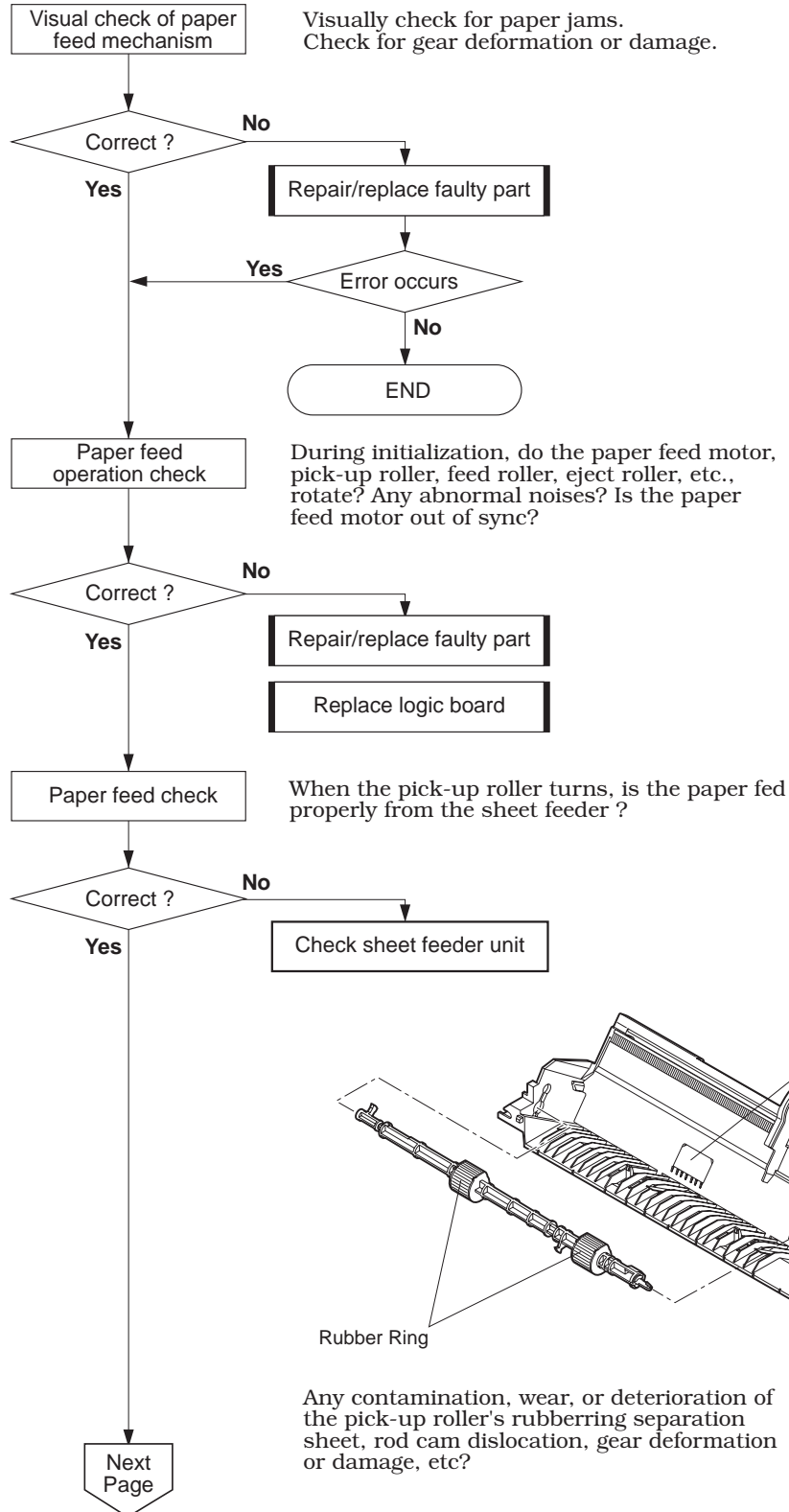

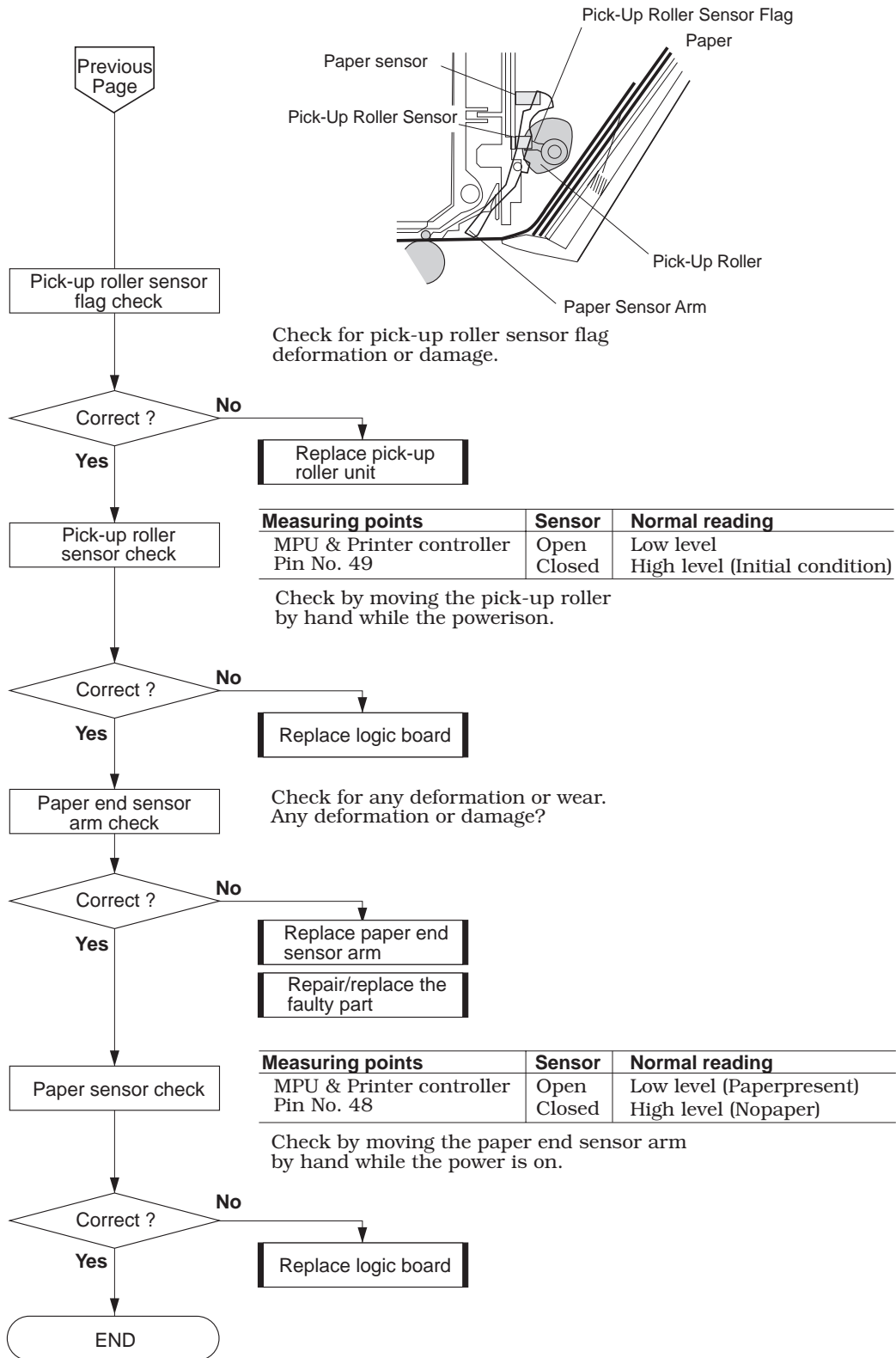

4. Waste Ink Full Error

<Cause> The waste ink absorbers' estimated waste ink amount has reached 100%.

<Suspected Parts> Waste ink absorbers, logic board

<Measures> 1. Reset the EEPROM and replace the bottom cover unit.
2. Replace logic board.

5. Printer Temperature Sensor Error (Code : 5400)

<Cause> Thermistor is abnormal.

<Suspected Parts> Thermistor

<Measures> Replace logic board.

6. Carriage Control Error (Code : 5100)

<Cause> The printing position correction value cannot be detected.

<Suspected Parts> Carriage motor, logic board, home position sensor

<Measures> See countermeasures for home position sensor error.

**7. Purging
Operation Error**
(Code : 5C00)

<Cause> Cleaning is not executed properly or not being detected.
<Suspected Parts> Home position sensor, sensor arm, purge unit, carriage ribbon cable, logic board

<Measure>

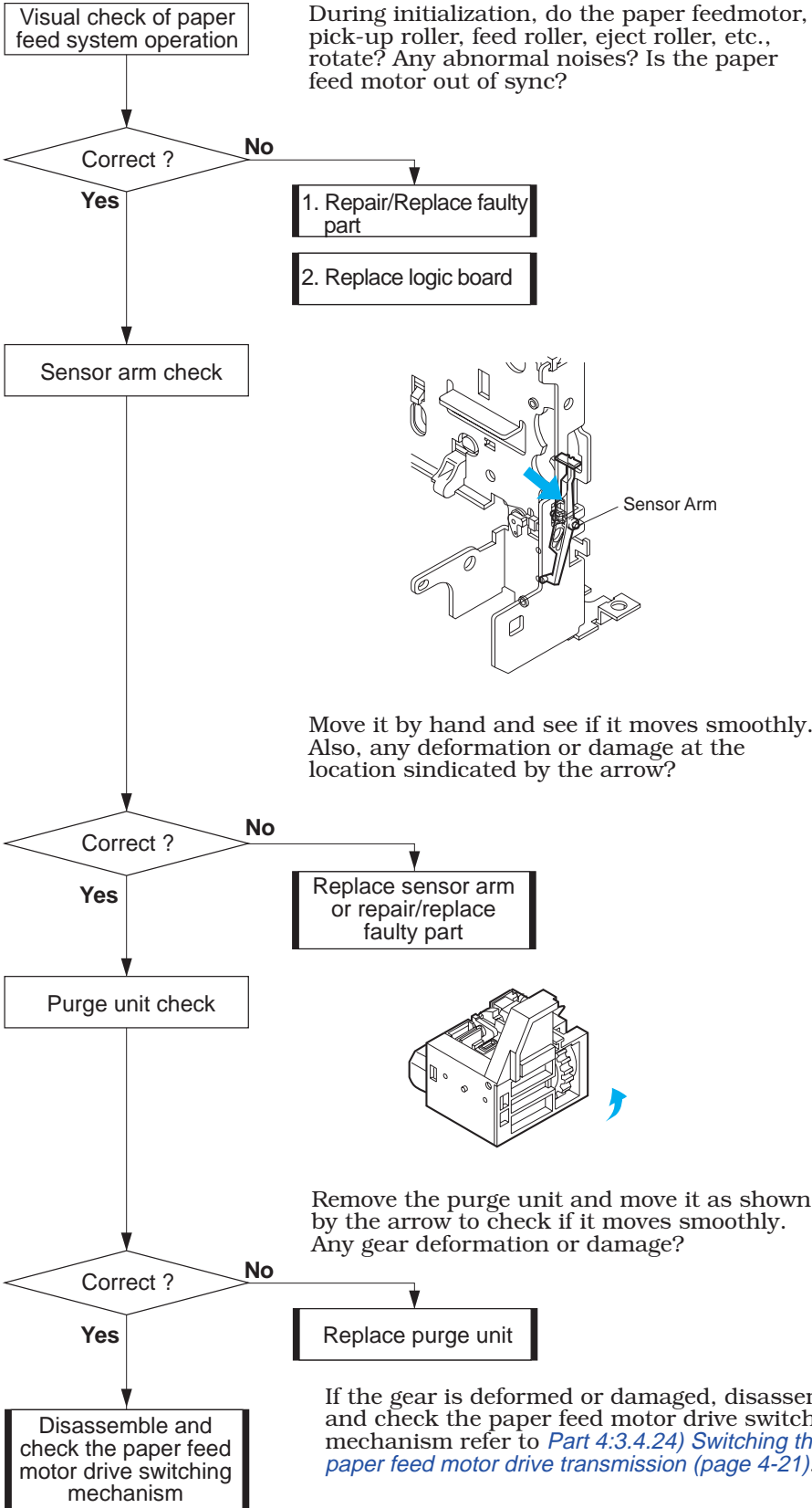

If the gear is deformed or damaged, disassemble and check the paper feed motor drive switching mechanism refer to [Part 4:3.4.24 Switching the paper feed motor drive transmission \(page 4-21\)](#).

b) Symptoms

1. The Power Does Not Turn On

<Symptom> The printer does not perform initializing even when the AC plug is connected.

<Cause> The AC adapter and/or control board is faulty.

<Measure>

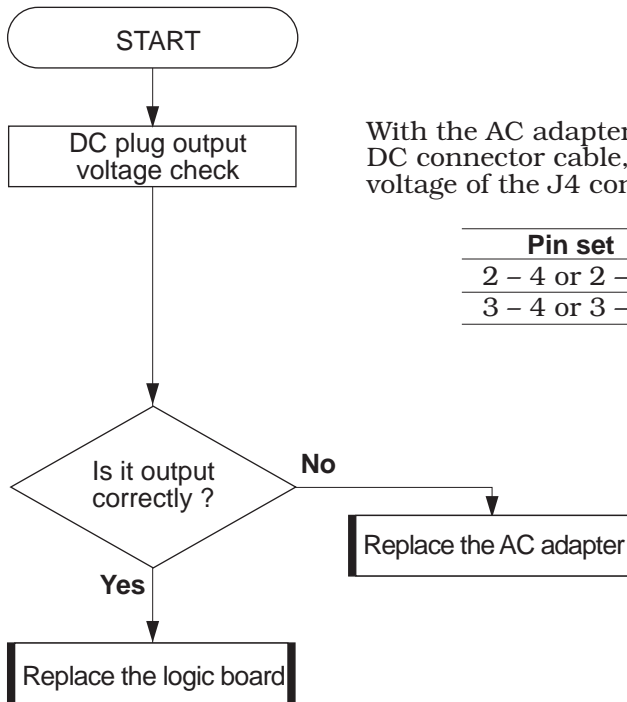

With the AC adapter and logic board connected by the DC connector cable, check and measure the output voltage of the J4 connector pins as shown below:

Pin set	Output voltage
2 - 4 or 2 - 5	+27.6 VDC
3 - 4 or 3 - 5	+5.0 VDC

2. The Printer Does Not Recognize The Cartridge

- <Symptom>**
- The cartridge installed is not recognized.
 - The installed cartridge is recognized incorrectly.
- <Cause>**
- Faulty contacts between the cartridge and carriage.
 - The cartridge is faulty.
 - The carriage ribbon cable is faulty.
 - The logic board is faulty.

<Measure>

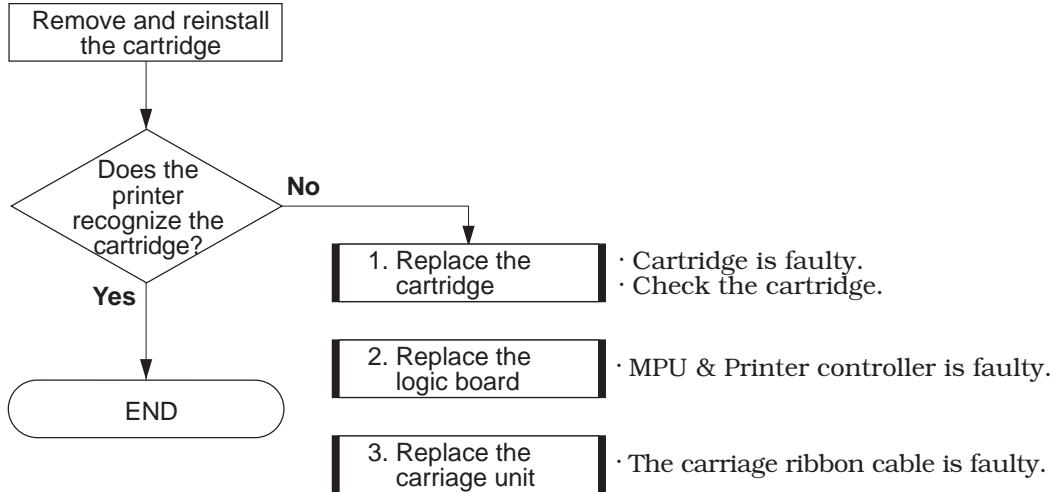

To confirm that the cartridge is not being recognized correctly, check for conductivity at the check points indicated in the diagram below.

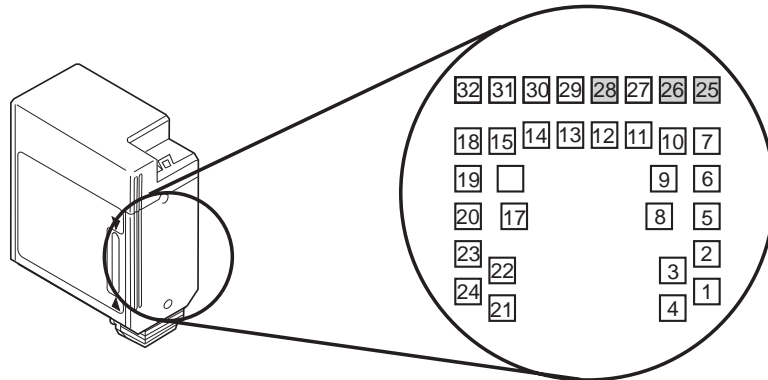

Black BJ Cartridge

Check	Normal reading
Pin No. 26-25	Approx. 0 Ω
Pin No. 28-25	∞

Color BJ Cartridge

Check	Normal reading
Pin No. 26-25	∞
Pin No. 28-25	Approx. 0 Ω

Photo BJ Cartridge

Check	Normal reading
Pin No. 26-25	∞
Pin No. 28-25	∞

3. Faulty Printing <1>: No Printing

- <Symptom>**
- The printer does not print at all.
 - Printing stops mid-way.
 - Only a certain color is printed.
- <Cause>**
- The ink has run out or the BJ cartridge is faulty.
 - The control board, the carriage ribbon cable, or the purge unit is faulty.

<Measure>

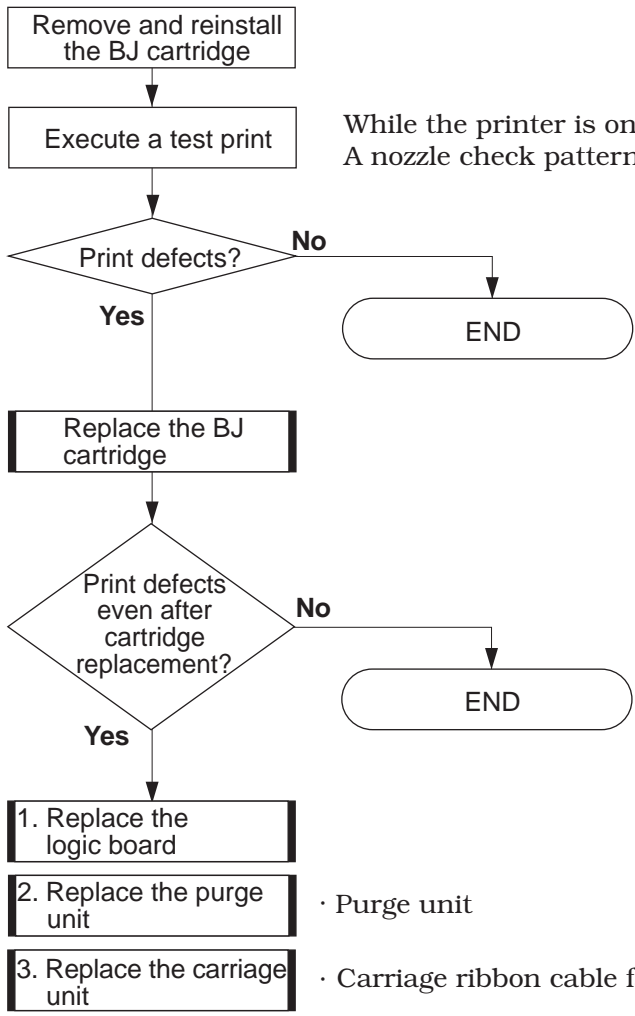

While the printer is on, double-click the *RESUME* button. A nozzle check pattern will be printed out.

4 Faulty Printing <2>: White Stripes Appear

- <Symptom>**
- There is blotching.
 - There are white stripes.
 - The specified dots are not printed.
- <Cause>**
- The BJ cartridge or cartridge contacts are faulty.
 - The carriage ribbon cable is faulty.
 - The purge unit or paper feed mechanism (missing gear tooth) is faulty.

<Measure>

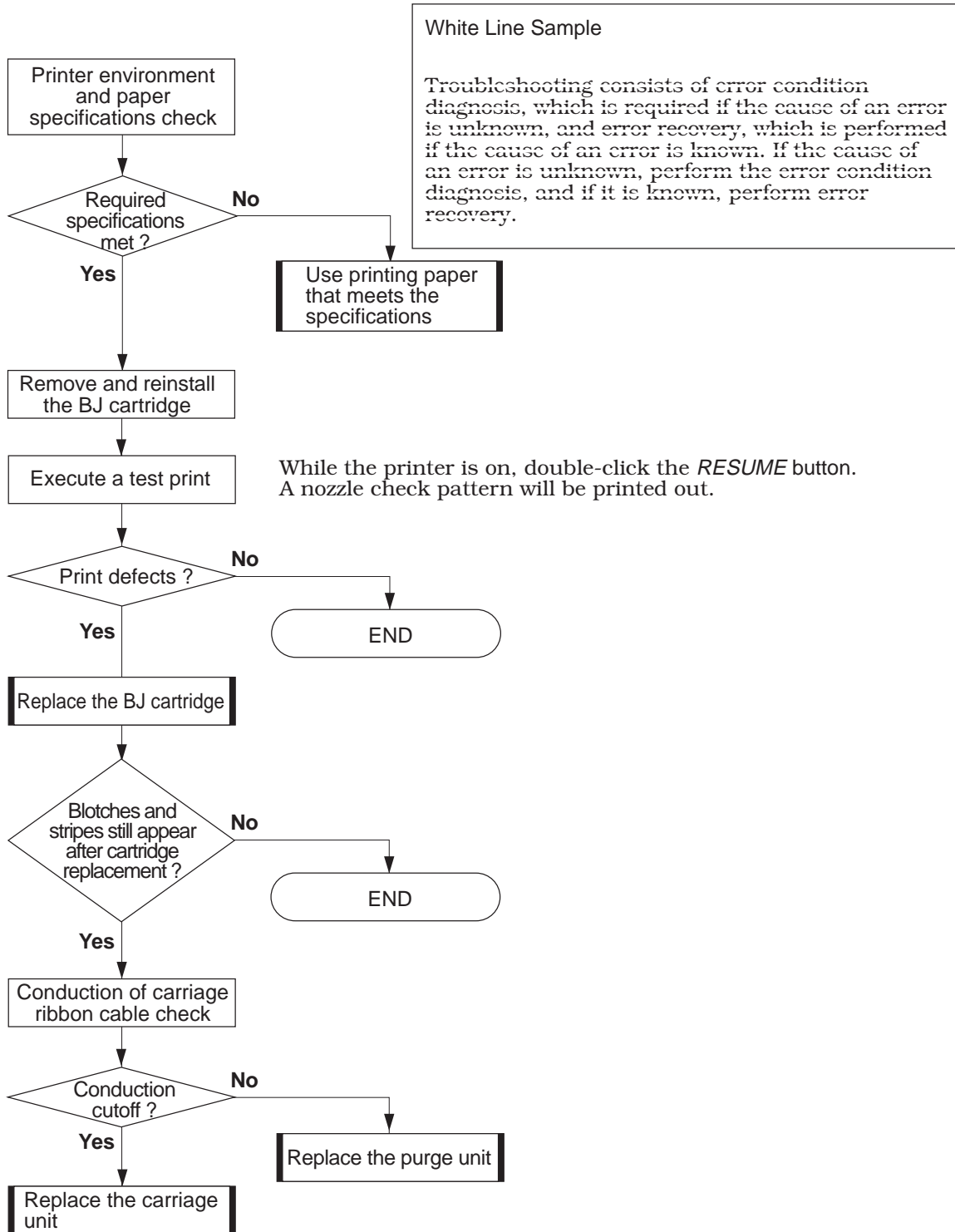

5 Faulty Printing <3>: Other Print Problems

Symptom	Check Item	Measures
Paper contamination	Ink mist on the platen.	Use a soft cloth moistened with water to clean.
	Ink has clogged around the head's nozzles. (No paper contamination during paper feeding and discharging.)	Perform cleaning operations several times. If problem persists, replace the BJ cartridge.
	Ink has clogged (or paper bits have stuck) around the purge unit's head wiper or head capping area.	Replace the purge unit.
	Ink has adhered to the paper transport system. (The paper is already contaminated by the time it reaches the platen.)	Disassemble the paper transport system and use a soft moist cloth to clean.
Spur tracks appear	Ink has adhered to the spurs.	Use a soft toothbrush to clean.
	The spurs are deformed.	Replace the front cover unit.
Vertically-oriented printed lines are misaligned.	The BJ cartridge is installed incorrectly.	Reinstall the BJ cartridge correctly.
	The paper thickness lever is not set properly.	Set the lever at the specified position.
	The problem occurs when the user's BJ cartridge (causing the problem) is installed in a normally-operating printer.	Replace the BJ cartridge.
Corrugated printing	The carriage guide frame is deformed.	Replace the printer frame unit.
	Frictional wear between the carriage base and carriage shaft.	Replace the carriage unit.
The printout is either light or dark.	Check the printing mode.	Set the desired printing mode.
	The BJ cartridge is faulty.	Replace the BJ cartridge.

6. Faulty Interface

- <Symptom>**
- Nothing is printed.
 - An unspecified font is printed.
 - An unspecified color is printed.
- <Cause>**
- The printer driver setting is faulty.
 - The interface cable is faulty.
 - The printer's logic board is faulty.

<Measure>

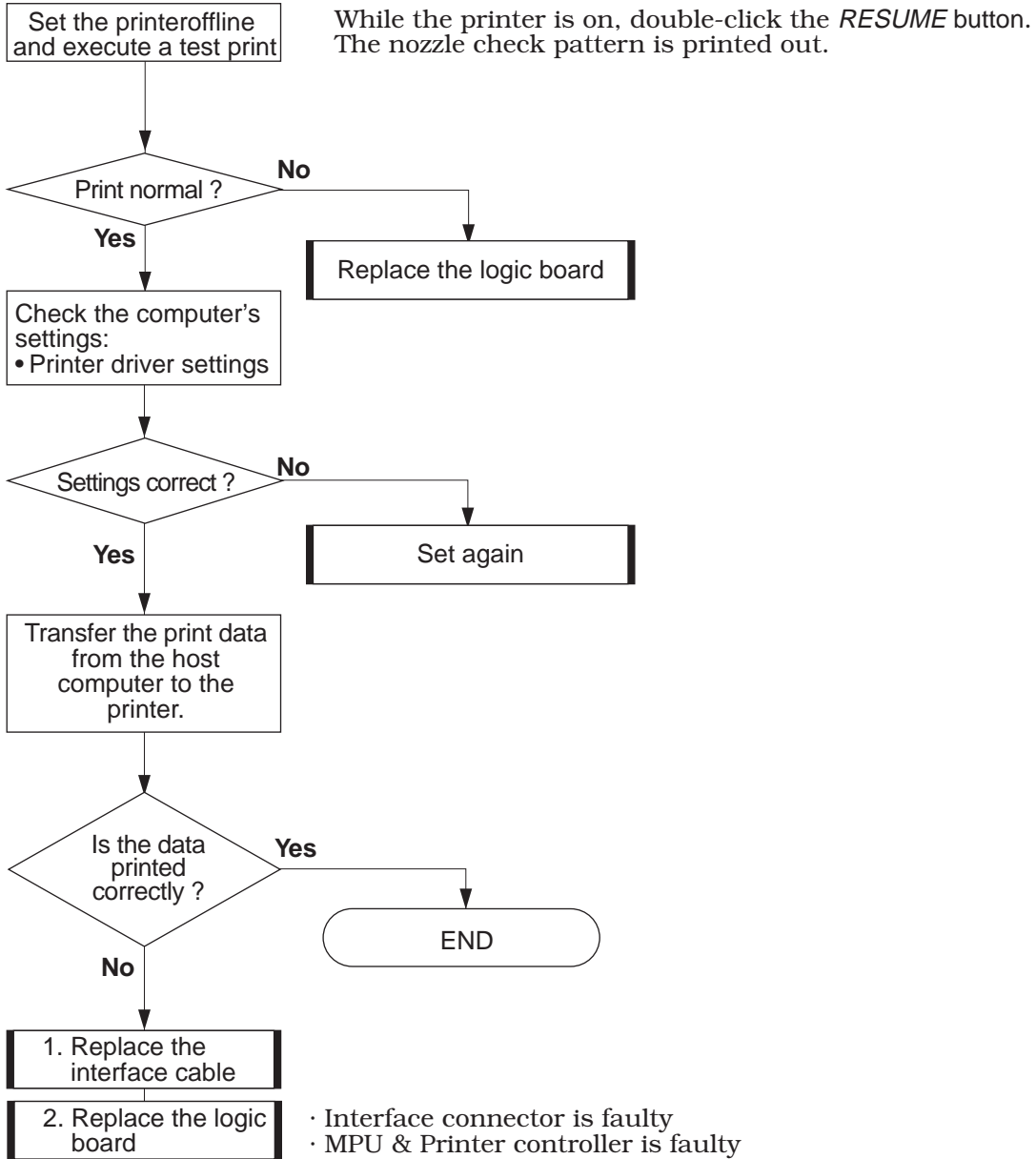

5. LOCATION & SIGNAL ASSIGNMENT

5.1 Logic Board

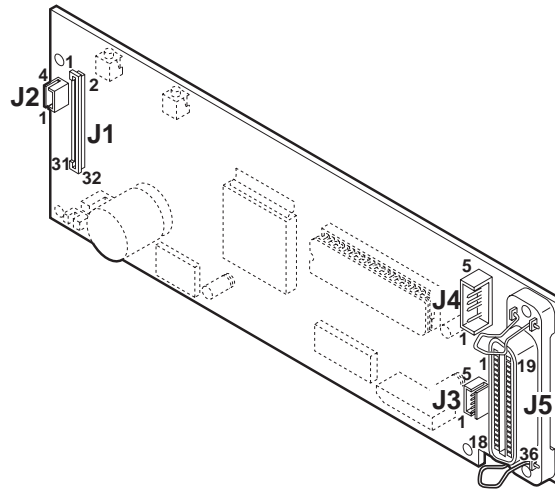

Figure 5-3 Logic Board

J1/CNH (Ribbon cable connector)

Pin No.	Signal name	IN/OUT	Description
1	Not used		
2	HPS-A	OUT	Photo LED drive
3	GND	...	Ground
4	HPS	IN	Home position sense High / Low (sense)
5	HSEG7	OUT	SEG7 heat enable
6	HCOM3	OUT	COM3 heat enable
7	GND	...	Ground for head rank
8	HRANK3	IN	Head rank sense
9	HRANK2	IN	Head rank sense
10	HRANK1	IN	Head rank sense
11	ID1	IN	BJ cartridge recognition signal (See Table 5-1.)
12	HCOM5	OUT	COM5 heat enable
13	ID3	IN	(Not used)
14	HCOM6	OUT	COM6 heat enable
15	ID2	IN	BJ cartridge recognition signal (See Table 5-1.)
16	GND	...	Ground
17	HCOM7	OUT	COM7 heat enable
18	HSEG3	OUT	SEG3 heat enable
19	HCOM4	OUT	COM4 heat enable
20	HSEG2	OUT	SEG2 heat enable
21	HCOM8	OUT	COM8 heat enable
22	HSEG1	OUT	SEG1 heat enable
23	HSEG4	OUT	SEG4 heat enable
24	HEATER	OUT	Warm-up heater voltage VH and Detection signal
25	GND	...	GND for warm-up heater voltage VH
26	HCOM2	OUT	COM2 heat enable
27	HCOM1	OUT	COM1 heat enable
28	HSEG8	OUT	SEG8 heat enable
29	HSEG6	OUT	SEG6 heat enable
30	HSEG5	OUT	SEG5 heat enable
31	HEATER	OUT	Warm-up heater voltage VH and Detection signal
32	GND	...	GND for warm-up heater voltage VH

J2/CNCR (Carriage motor connector)

Pin No.	Signal name	IN/OUT	Description
1	CRA	OUT	Carriage motor phase A
2	CRA	OUT	Carriage motor phase \bar{A}
3	CRB	OUT	Carriage motor phase B
4	CRB	OUT	Carriage motor phase \bar{B}

J3/CNLF (Paper feed motor connector)

Pin No.	Signal name	IN/OUT	Description
1	LFA	OUT	Paper feed motor phase A
2	LFA	OUT	Paper feed motor phase \bar{A}
3	VM	...	Common
4	LFB	OUT	Paper feed motor phase \bar{B}
5	LFB	OUT	Paper feed motor phase B

J4/CNPS (Power Supply connector)

Pin No.	Signal name	IN/OUT	Description
1	Change VH	OUT	
2	V _H	IN	27.6 VDC
3	V _{cc}	IN	5 VDC
4	GND	...	Ground
5	GND	...	Ground

J5/CINF (Interface connector)

Pin No.	Signal name	IN/OUT	Description
1	STROBE	IN	See <i>Part 2: 2.3 Interface Specifications (page 2-9)</i> for details.
2	DATA1	IN	
3	DATA2	IN	
4	DATA3	IN	
5	DATA4	IN	
6	DATA5	IN	
7	DATA6	IN	
8	DATA7	IN	
9	DATA8	IN	
10	ACKNLG	OUT	
11	BUSY	OUT	
12	P.E.	OUT	
13	SELECT	OUT	
14	AUTO FEED XT	IN	
15	N.C.	...	
16	INIT	IN	
17	GND	...	
18	N.C.	...	
19	STROBE-RET	...	
20	DATA1-RET	...	
21	DATA2-RET	...	
22	DATA3-RET	...	
23	DATA4-RET	...	
24	DATA5-RET	...	
25	DATA6-RET	...	
26	DATA7-RET	...	
27	DATA8-RET	...	
28	ACKNLG-RET	...	
29	BUSY-RET	...	
30	P.E.-RET	...	
31	INIT	IN	
32	ERROR	OUT	
33	GND	...	
34	N.C.	...	
35	+5.0V	...	
36	SELECT IN	IN	

5.2 Carriage Ribbon Cable

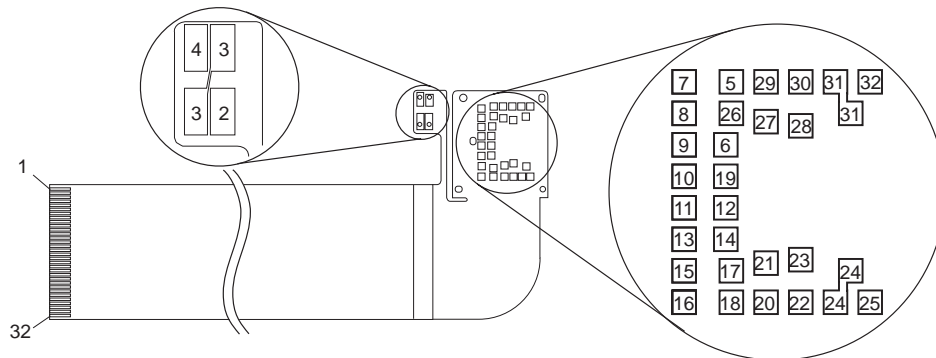

Figure 5-4 Carriage Ribbon Cable

Pin No.	Signal name	IN/OUT	Description	BJ cartridge pin no.
1	Not used			-
2	HPS-A	OUT	Photo LED drive	-
3	GND	...	Ground	-
4	HPS	IN	Home position sense High / Low (sense)	-
5	HSEG7	OUT	SEG7 heat enable	18
6	HCOM3	OUT	COM3 heat enable	14
7	GND	...	Ground for head rank	32
8	HRANK3	IN	Head rank sense	31
9	HRANK2	IN	Head rank sense	30
10	HRANK1	IN	Head rank sense	29
11	ID1	IN	BJ cartridge recognition signal (See Table 5-1.)	28
12	HCOM5	OUT	COM5 heat enable	12
13	ID3	IN	(Not used)	27
14	HCOM6	OUT	COM6 heat enable	11
15	ID2	IN	BJ cartridge recognition signal (See Table 5-1.)	26
16	GND	...	Ground	25
17	HCOM7	OUT	COM7 heat enable	10
18	HSEG3	OUT	SEG3 heat enable	7
19	HCOM4	OUT	COM4 heat enable	13
20	HSEG2	OUT	SEG2 heat enable	6
21	HCOM8	OUT	COM8 heat enable	9
22	HSEG1	OUT	SEG1 heat enable	5
23	HSEG4	OUT	SEG4 heat enable	8
24	HEATER	OUT	Warm-up heater voltage VH and Detection signal	2,3
25	GND	...	GND for warm-up heater voltage VH	1
26	HCOM2	OUT	COM2 heat enable	15
27	HCOM1	OUT	COM1 heat enable	16
28	HSEG8	OUT	SEG8 heat enable	17
29	HSEG6	OUT	SEG6 heat enable	19
30	HSEG5	OUT	SEG5 heat enable	20
31	HEATER	OUT	Warm-up heater voltage VH and Detection signal	22,23
32	GND	...	GND for warm-up heater voltage VH	24

Cartridge types BC-02, BC-05 and BC-06 can be distinguished with combinations of the ID1 and ID2 signals as shown in the table below.

TABLE 5-1 BJ CARTRIDGE RECOGNITION

J1 pin no.	BJ cartridge pin no.	Signal name	Cartridge type		
			BC-02	BC-05	BC-06
15	26	ID2	Low	High	High
11	28	ID1	High	Low	High

5.3 BJ Cartridges

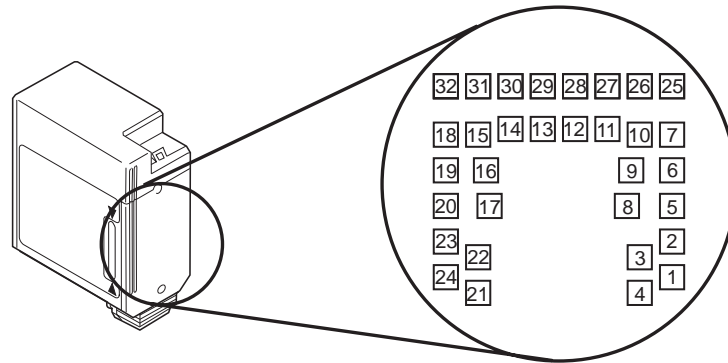

Figure 5-5 Contact Pad

BLACK BJ CARTRIDGE

Pin No.	Signal name	IN/OUT	Description	J1 pin no.
1	HGND1	OUT	GND for warm-up heater voltage VH	25
2	HEATER1	IN	Warm-up heater voltage VH and Detection signal	24
3	TMPSEN1A	IN	Temperature sensor 1, anode (Not Used)	24
4	TMPSEN1C	OUT	Temperature sensor 1, cathode (Not Used)	-
5~8	SEG1~4	IN	SEG1~4 heat enable	22,20,18,23
9~16	COM1~8	IN	COM1~8 heat enable	21,17,14,12
17~20	SEG8~5	IN	SEG8~5 heat enable	19,6,26,27
21	TMPSEN2C	OUT	Temperature sensor 2, cathode (Not Used)	-
22	TMPSEN2A	IN	Temperature sensor 2, anode (Not Used)	31
23	HEATER2	IN	Warm-up heater voltage VH and Detection signal	31
24	HGND2	OUT	GND for warm-up heater voltage VH	32
25	GND	GND		16
26	ID2	OUT	BJ cartridge recognition signal	15
27	Not used	...		13
28	ID1	OUT	BJ cartridge recognition signal	11
29~32	HRANK		Head rank	10,9,8,7

COLOR/PHOTO BJ CARTRIDGE

Pin No.	Signal name	IN/OUT	Description	J1 pin no.
1	HGND1	OUT	GND for warm-up heater voltage VH	25
2	Not used	...		24
3	HEATER1	IN	Warm-up heater voltage VH and Detection signal	24
4	Not used	...		-
5~8	SEG1~4	IN	SEG1~4 heat enable	22,20,18,23
9~10	COM1~2	IN	COM1~2 heat enable (Cyan)	21,17
11	Not used	...		14
12~13	COM4~5	IN	COM4~5 heat enable (Magenta)	12,19
14	Not used	...		6
15~16	COM7~8	IN	COM7~8 heat enable (Yellow)	26,27
17~20	SEG8~5	IN	SEG8~5 heat enable	28,5,29,30
21	Not used	...		-
22	HEATER2	IN	Warm-up heater voltage VH and Detection signal	31
23	Not used	...		31
24	HGND2	OUT	GND for warm-up heater voltage VH	32
25	GND	GND		16
26	ID2	OUT	BJ cartridge recognition signal	15
27	GND	GND		13
28	ID1	OUT	BJ cartridge recognition signal	11
29~32	HRANK		Head rank	10,9,8,7

6. CIRCUIT DIAGRAMS

6.1 Parts Layout 6.1.1 Logic board

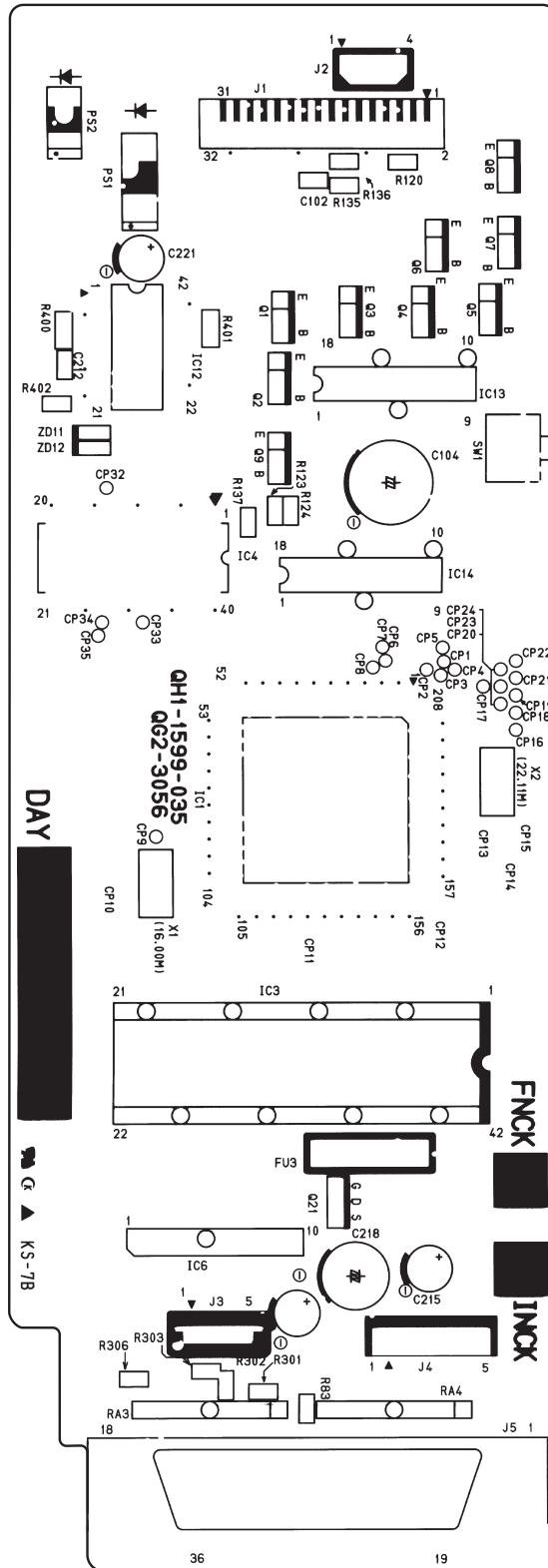

Figure 5-6 Logic Board (Top View)

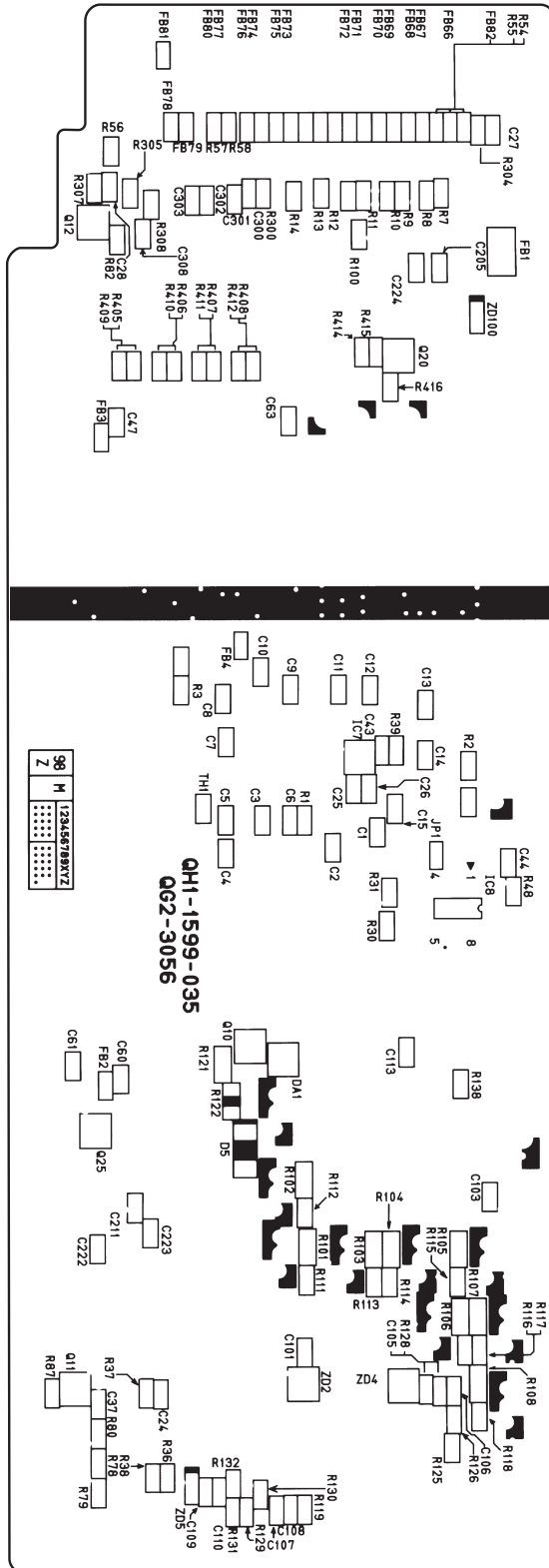
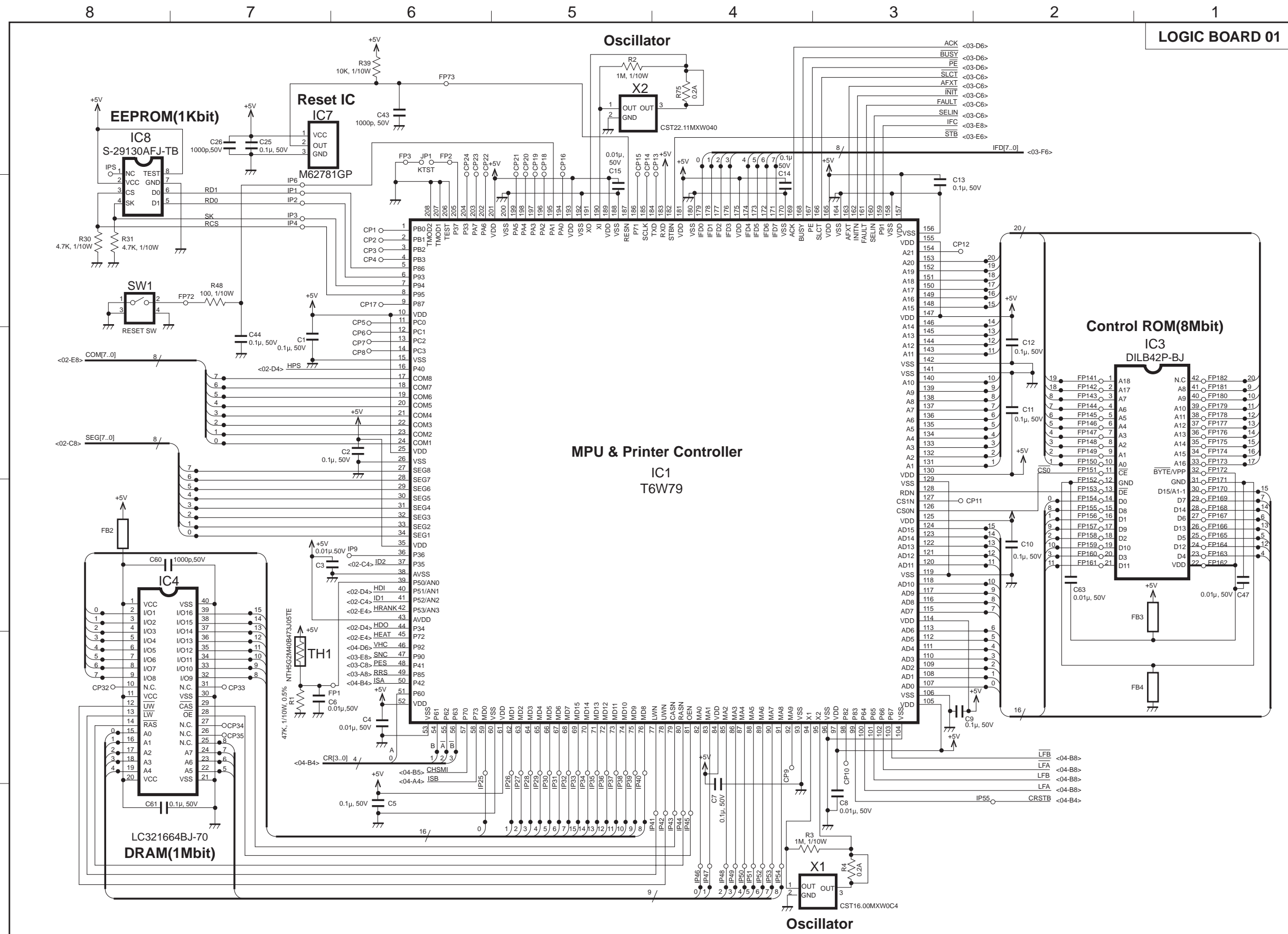
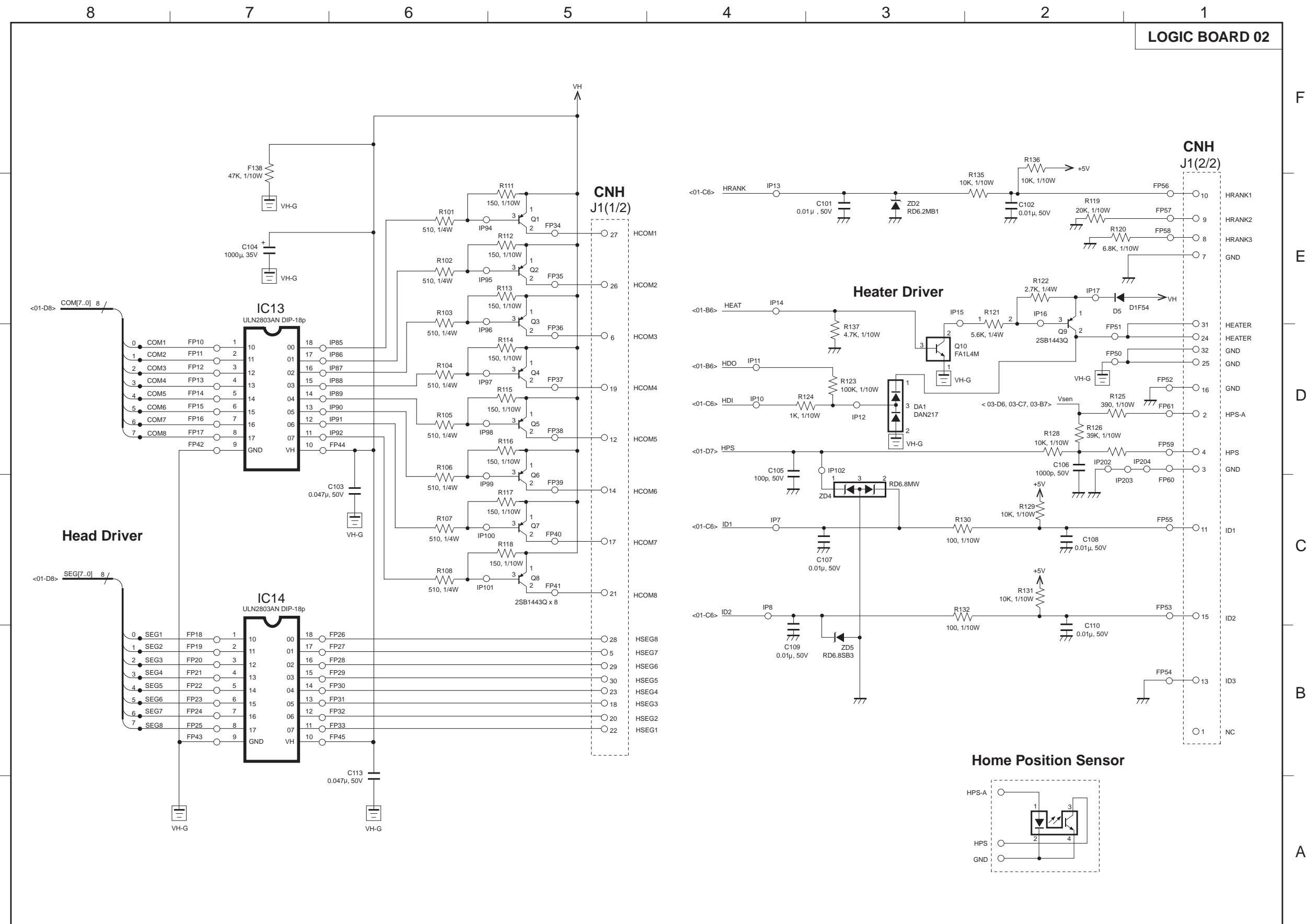
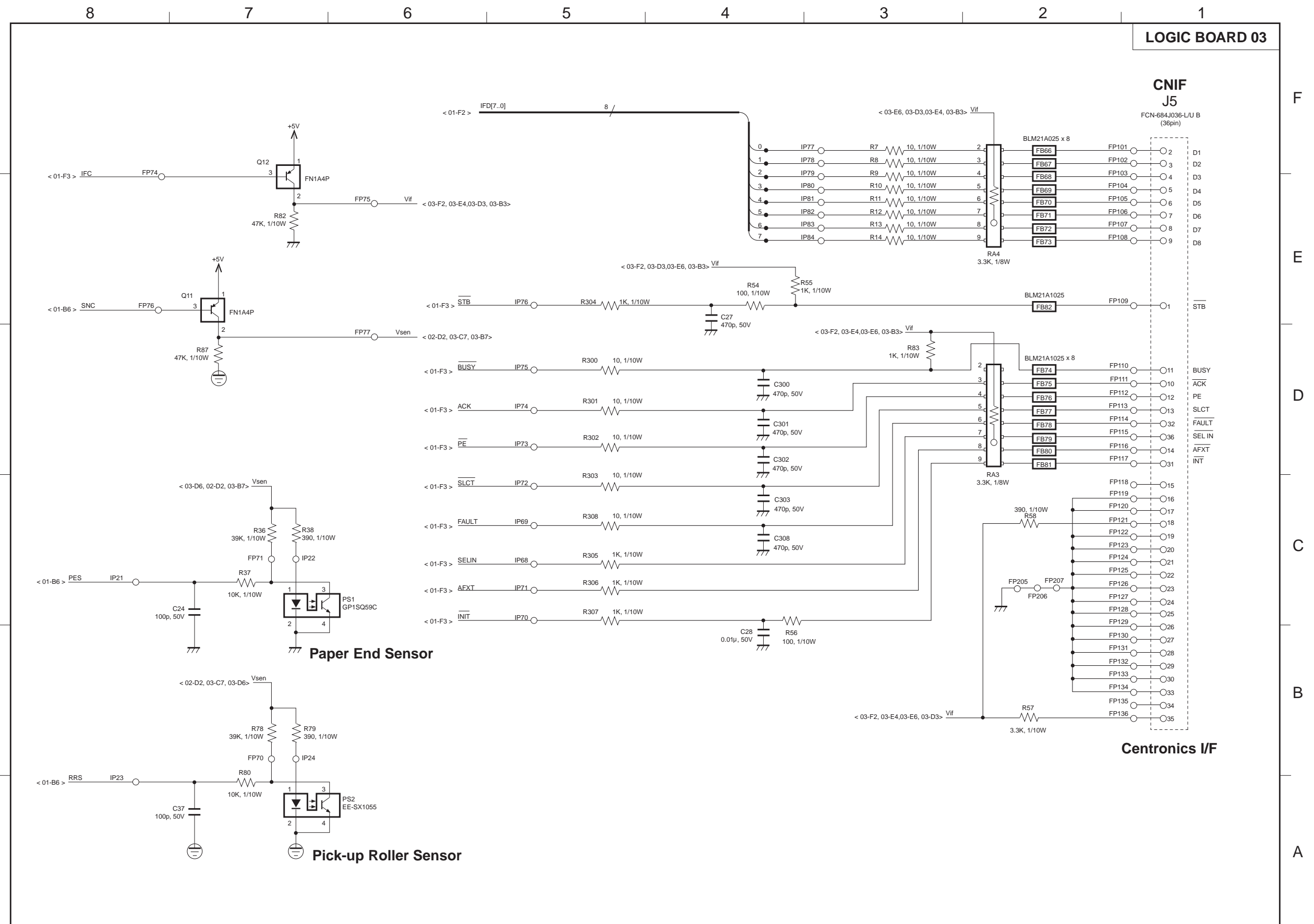

Figure 5-7 Logic Board (Bottom View)

6.2 Circuit Diagrams







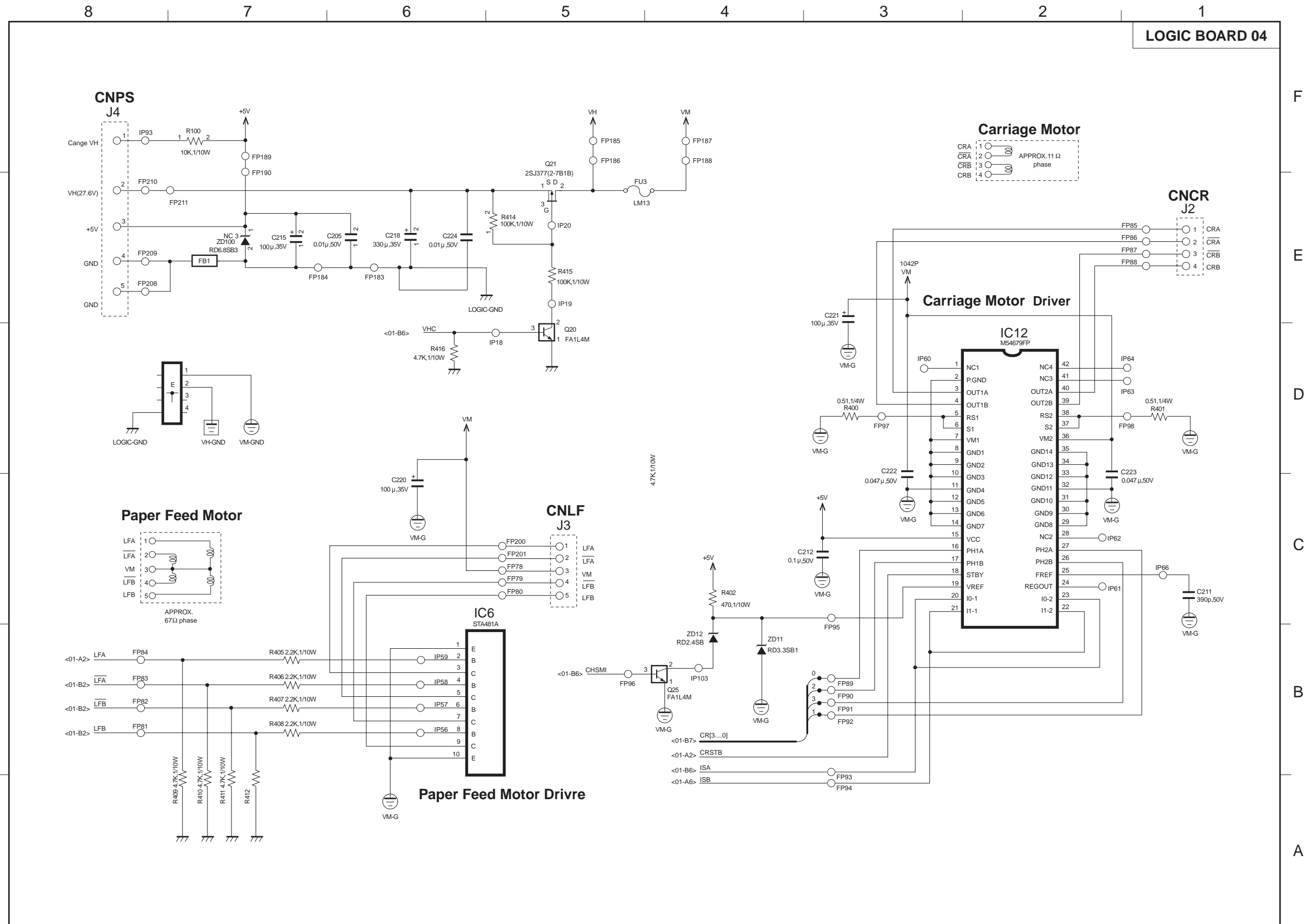



The printing paper contains
70% waste paper.

Canon